



140G

MOTOR GRADER

- **Reliable/Durable** — built to withstand the toughest working conditions.
- **Operating Ease** — effortless power shifting, precise blade controls, and exceptional maneuverability for all-around production.
- **Low Operating Cost** — highly efficient, long-life components.
- **Operator Comfort and Convenience** — efficient, productive work environment.
- **Total Customer Support System** — unmatched in the industry.

Cat® 3306 turbocharged diesel Engine available in two power arrangements:

| | |
|--|---------------------|
| Standard (all gears) | 112 kW/150 HP |
| Variable Horsepower (VHP) Arrangement: | |
| Gears 1 and 2 | 112 kW/150 HP |
| Gears 3 through 6 | 134 kW/180 HP |
| Blade width | 3658 mm/12 ft |
| *Operating weight | 15 628 kg/34,380 lb |

* Equipped with ripper-scaffer, push-plate, 4267 mm/14' blade with hydraulic sideshift and tip, 14'00-24", 10 PR (G-2) tires with 10" rims, and low profile cab. Machine shown may include optional equipment.



Courtesy of Machine Market

FEATURES

Caterpillar® Power Train

Designed for durability and efficiency.

Cat Diesel Engine... Caterpillar four-stroke cycle engines blend power and efficiency.

- Long, effective power strokes... more complete fuel combustion.
- Direct-injection fuel system for efficient, precise fuel metering.
- Engine flywheel faces rearward, sending transmission noise and vibration away from the operator.



Variable Horsepower Arrangement Available

- 112 kW/150 HP in gears 1 and 2
- 134 kW/180 HP in gears 3-6
- 20% more work power in third through sixth gear.
- Higher rimpull to keep graders moving through tough spots.
- More horsepower for higher speed blading operations.
- High gear selection... faster travel speeds to and from job.

Direct-Drive, Power Shift Transmission...

designed specifically for motor graders.

- The feel and efficiency of direct drive.
- Easy on-the-go shifting up or down, forward or reverse.
- Clutch plates are continuously lubricated and cooled by oil.
- Oil-disc parking brake, manually applied.

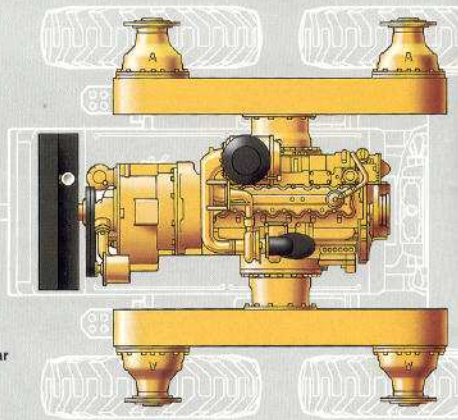
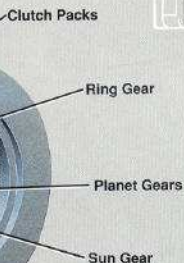
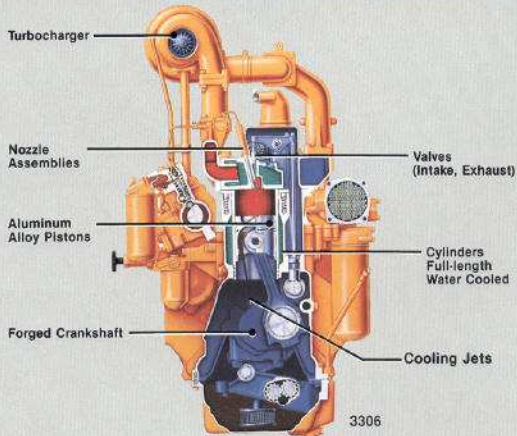



Optional Equipment

(with approximate installed weights)

| | Kg | Lb | | Kg | Lb |
|--|------|------|--|------|------|
| Adjustable suspension seat | 59 | 130 | Jack, hydraulic | 9 | 21 |
| Air conditioner/heater | 84 | 186 | Lighting systems: | | |
| Air dryer | 18 | 39 | Work lights, center and rear | 6 | 13 |
| Blade 4267 mm/14' | 75 | 166 | Cab directional and | | |
| Blade extension, 610 mm/2' | | | cab headlights | 9 | 20 |
| Right | 91 | 200 | Cab directional, | | |
| Left | 91 | 200 | cab headlights and bar-mounted | | |
| Blade float, hydraulics | 46 | 102 | flood lights | 13 | 28 |
| Blade lift accumulator | 71 | 156 | Bar directional lights and | | |
| Cab, ROPS, full height, | | | bar headlights | 9 | 20 |
| sound suppressed | 54 | 120 | Warning light, beacon, rotating | | |
| Canopy, ROPS, includes | | | amber lens for cab-equipped | | |
| rear wall with window | | | machines only | 3 | 6 |
| Full height | -150 | -330 | Mirrors, outside, right and left, | | |
| Low profile | -200 | -440 | for cab or canopy | 8 | 18 |
| Clutch, slip for circle drive | 16 | 35 | Push plate | 461 | 1017 |
| Cutting edges, 203 x 19 mm/8 x 0.75' | | | Rims, 254 mm/10", set of six, | | |
| with reversible overlay end bits: | | | for use with 14.00 - 24" tires | 160 | 346 |
| 3658 mm/12' blade | 46 | 102 | Ripper-scarifier, includes 3 shanks | 1060 | 2336 |
| 4267 mm/14' blade | 73 | 161 | Scarifier, front V-type, 11 teeth | 845 | 1862 |
| Cylinder extension, centershift | 14 | 30 | Starting system, low temperature | 95 | 209 |
| Defroster fan, rear | 2 | 4 | Steering system, supplemental | 50 | 111 |
| Differential, tandem drive train, | | | Tires, (set of six): | | |
| with lock-unlock | 45 | 99 | 14.00 - 24", 12 PR traction | 94 | 207 |
| End bits, reversible overlay (set of 2) ... | 17 | 38 | 17.50 - 25", 12 PR traction, | | |
| Engine compartment doors | 110 | 242 | including wheels | 427 | 941 |
| Heater/pressurizer, cab includes | | | Tool Kit | 8 | 18 |
| hoses, engine coolant | 34 | 76 | Transmission guard | 168 | 371 |
| Heater, cab includes hoses, | | | Vandalism protection: | | |
| engine coolant | 10 | 23 | an instrument panel guard and | | |
| Hydraulic arrangements with one or more additional | | | cap locks, transmission gauge fill | | |
| hydraulic valves are available for hydraulic blade | | | dipstick and engine oil fill dipstick | 8.6 | 19 |
| sideshift, tip, V-type scarifier and rear-mounted | | | Variable horsepower arrangement | 5 | 10 |
| ripper-scarifier, and for attachments from other | | | Windshield wiper, rear | 4 | 9 |
| suppliers, such as snow plows, snow wings and | | | | | |
| bulldozers. | | | | | |

SPECIFICATIONS



Standard Equipment

NOTE: Standard and optional equipment may vary. Consult your Caterpillar Dealer for specifics.

24 Volt electrical system.
Accelerator/decelerator.
Adjustable control console.
Adjustable suspension seat.
Alternator, 50-amp.
Articulated frame.
Articulation indicator.
Backup alarm
(meets SAE J994).

Blower fan.
Cap locks.
Coolant temperature gauge.
Drawbar, six shoe,
with replaceable bronze-alloy
wear strips.
Dry-type air cleaner with service
indicator and automatic dust
ejector.

Electronic Monitoring System
(EMS).
Ether start.
Four-wheel, oil disc brakes.
Hand governor control.
Horn (meets SAE J1105).
Heavy-duty starting motor.
Hydraulic (controls, steering, and
front wheel lean).
Inside rearview mirror.
Maintenance-free batteries.
Moldboard,
3658 mm/12' mechanical side-
shift moldboard with manual
tip, 152 x 16 mm/6 x 0.62" DH2
steel cutting edges.

Muffler.
Parking brake.
Power shift transmission.
Prescreener.
Rear drawbar.
Seat belt (meets SAE J326).
Service meter.
Sound suppressed, low-profile
ROPS cab.
Steering wheel, tilt,
control console.
Stop and tail lights.
Tool box.
Traction tires, 14.00 - 24",
10 PR (G2).
Windshield washer and wipers.



Blade Range

| | |
|---|--------------------------|
| Circle centershift, right | 521 mm/20.5" |
| Left | 648 mm/25.5" |
| Moldboard sideshift, hydraulic, | |
| Right | 670 mm/26.5" |
| Left | 520 mm/20.5" |
| Maximum shoulder reach outside of tires,* | |
| Right | 1829 mm/6'0" |
| Left | 1803 mm/5'11" |
| Maximum blade position, angle, both sides | 90°** |
| Maximum lift above ground | 464 mm/18.25" |
| Maximum depth of cut | 438 mm/17.75" |
| Hydraulic blade tip | 40° forward; 5° rearward |

*Add 305 mm/12" right or left for 4267 mm/14' blade.
With main frame in crab position, add 939 mm/3'1" right or left.

**Mid-range bank sloping (2:1) capability requires addition of optional centershift cylinder extension.



Hydraulic Controls

Full hydraulic controls provide fast, constant control speed regardless of engine speed. Lock valves in each implement circuit minimizes drift. Operator controls all blading operations with six levers: left blade lift, sideshift, blade tip, circle reverse, centershift and right blade lift. Hydraulic system lets operator use more than one control without decrease in control response speed.

Blade lift accumulator system provides cushioning action for blade lift hydraulic circuits. Recommended for use on maintenance of hard, rocky roads. Includes on-off control.



Steering

| | |
|---|-------------------|
| Front wheels — full two cylinder hydraulic steering system. | |
| Steering range | 50° left or right |
| Frame — hydraulically actuated steering | 20° left or right |
| Minimum turning radius (outside front tires) | 7.3 m/24' |

*Using front wheel steering, wheel lean, frame articulation and differential unlock.



Load-Sensing Hydraulics

The closed center variable displacement pressure pump senses a load requirement from an implement or steering and increases the output pressure to 2067 kPa/21 bar/300 psi above the load. With no requirement, the pump maintains 2965 kPa/29.6 bar/430 psi output pressure. This reduces heat generation, increases hydraulic efficiency, and improves fuel economy. Hydraulic lock valves in all implement circuits minimize undesirable cylinder drift.

Output at 2200 engine RPM and 2965 kPa/29.6 bar/
430 psi to 24 133 kPa/241 bar/3500 psi
.....0 to 208 liters/min/0 to 55 gpm



Drawbar

Box-section, 140 x 89 x 13 mm/5.5" x 3.5" x 0.5" A-frame with six widely spaced shoes to support the circle. All have vertical and horizontal adjustment. Replaceable **bronze-alloy wear strips** between circle and drawbar, and support shoes and circle eliminate circle shoe grease fittings and extend wear life.



Circle

Rolled ring forging, 1530 mm/60.3" diameter. Uniform, flame-cut teeth. Raised wear surfaces, top and bottom, prevent circle teeth from contacting support shoes. Hydraulically driven worm and gear provide full 360° circle rotation. Optional circle drive slip clutch.

Blade beam — thickness

32 mm/1.25"

SPECIFICATIONS



Operating Weight (approximate)

Basic operating weight includes lubricants, coolant, full fuel tank, operator, 3658 mm/12' blade and 14.00 - 24", 10 PR (G-2) traction-type tires and low profile ROPS cab (standard in U.S.):

| | Kg | Lb |
|------------------------------|--------|--------|
| Weight on front wheels | 4076 | 8967 |
| Weight on rear wheels | 9467 | 20,828 |
| Total weight..... | 13 543 | 29,795 |

Equipped as above and including ripper-scarifier, front-mounted push plate, and 4267 mm/14' blade with hydraulic sideshift and tip, hydraulic control group and 10' rims.

| | Kg | Lb |
|------------------------------|--------|--------|
| Weight on front wheels | 4415 | 9712 |
| Weight on rear wheels..... | 11 213 | 24,668 |
| Total weight..... | 15 628 | 34,380 |

Add or subtract weights of additional equipment from Attachment Selection list to obtain total equipped operating weight.



Scarifier Specifications

| Scarifier Placement Type | Front-Mounted | | Rear-Mounted |
|---|------------------|--------------|---------------|
| | V-Type | Straight | Ripper |
| Working width | 1184 in 46.6" | 1800 71" | 2197 86.5" |
| Scarifying depth, maximum | 282 in 11.1" | 317 12.5" | 282 11.1" |
| Ripping depth, maximum | — in — | — — | 434 17.1" |
| Scarifier shank holders, number | 11 | 17 | 9 |
| spacing..... | 117 in 4.6" | 111 4.38" | 270 10.5" |
| Ripper shank holders, number | — | — | 5 |
| spacing..... | — in — | — — | 533 21" |
| Increase in machine length, beam raised | — in — | — — | 1189 46.8" |



Service Refill Capacities

| | Liters | U.S. Gallons |
|--|--------|--------------|
| Fuel tank | 282 | 75 |
| Radiator..... | 40 | 10.6 |
| Crankcase..... | 27 | 7.1 |
| Transmission differential and final drive..... | 83 | 21.9 |
| Tandem housings (each)..... | 64 | 17 |
| Hydraulic system | 76 | 20 |

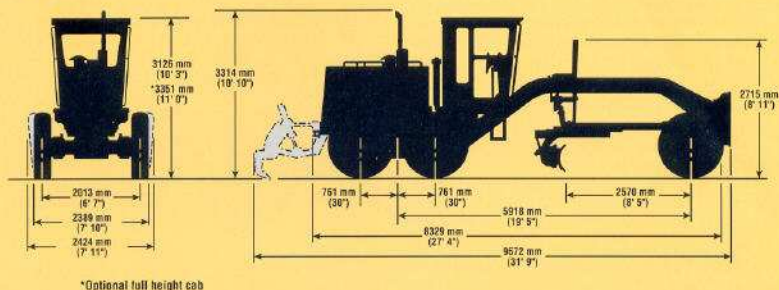

Dimensions (approximate)
**Frame**

Main frame – flanged, box-section structure runs from front bolster to the articulation joint.

Top and bottom plates –
width x thickness 305 x 22 mm/12" x .88"

Side plates –
height x thickness 248 x 13 mm/9.75" x 0.5"

Linear weight
(min–max) 123–163 kg/m/82–109 lb/ft

Vertical section
modulus (min–max) 1399–3180 cm³/85–194 in³

Rear frame – two box-sectioned channels integral with final drive case.

**Wheels**

Interchangeable rim and wheel assemblies. Tubeless tires, six 14.00 – 24, 10 PR (G2) traction-type.

**ROPS**

ROPS (Rollover Protective Structures) offered by Caterpillar for this machine meet ROPS criteria: SAE J396, SAE J1040 APR88 and ISO 3471-1986. They also meet FOPS (Falling Object Protective Structure) criteria SAE J231 JAN81 and ISO 3449-1984.

**Moldboard**

Wear-resistant, high-carbon steel, with box-section reinforcement. Induction-hardened sideshift rails.

Length x height x
thickness 3658 x 610 x 22 mm/12' x 24" x .88"

Cutting edge – Caterpillar through-hardened, curved DH2 steel.

Width x thickness 152 x 16 mm/6 x .62"

**Cab**

When properly installed and maintained, cab with doors and windows closed meets OSHA and MSHA requirements for operator sound exposure limits in effect at time of manufacture when tested according to ANSI/SAE J1166 FEB87. Equipped with 3" wide seat belt which meets SAE J53.

SPECIFICATIONS



Caterpillar Engine

Two arrangements available:
Standard (all gears).....112 kW/150 HP
Variable Horsepower

Gears 1 and 2.....112 kW/150 HP
Gears 3 through 6.....134 kW/180 HP
(Kilowatts (kW) is the International System of Units equivalent of horsepower.)

The net power at the flywheel of the vehicle engine operating under SAE J1349 standard conditions, 25° C/77° F and 100 kPa/29.61" Hg. Power is based on using 35° LHV of 42 780kJ/kg(18,390 Btu/lb) when used at 29.4°C/85°F and with a density of 838.9g/L(7.001 lb/U.S. gal.). Power rating is adjusted for vehicle equipped with fan, air cleaner, water pump, lubricating oil pump, fuel pump, and muffler. No derating is required up to 3000 m/10,000 ft. altitude.

Caterpillar four-stroke-cycle 3306 turbocharged diesel Engine with six cylinders, 121 mm/4.75 in. bore, 152 mm/6 in. stroke, and 10.5 liters/638 in.³ piston displacement.

Caterpillar, direct-injection fuel system with individual, adjustment-free injection pumps and valves.

Cam-ground and tapered, aluminum-alloy pistons have three-rings each; both compression rings ride in iron band cast into piston. Piston undersides are cooled by oil spray. Steel-backed, aluminum-alloy precision bearings. High-carbon steel alloy crankshaft with hardened journals. Pressure lubrication with full-flow filtered oil and oil cooler. Dry-type air cleaner with primary and secondary elements, automatic dust ejector and service indicator.

Direct-electric, 24-volt starting system with 50-amp alternator, heavy-duty starter, ether starting aid and maintenance-free batteries.



Transmission

Caterpillar direct-drive power shift. Single lever at operator's right controls six forward and six reverse speeds. Foot pedal provides inching capability for close-quarter maneuvering. Transmission lock prevents accidental gear engagement, machine won't move even if engine is started with transmission engaged.

Speeds (at rated RPM):

| Forward & Reverse | 1st | 2nd | 3rd | 4th | 5th | 6th |
|-------------------|-----|-----|-----|------|------|------|
| Km/h | 3.9 | 6.3 | 9.8 | 16.3 | 26.1 | 41.0 |
| MPH | 2.4 | 3.9 | 6.1 | 10.1 | 16.2 | 25.5 |



Brakes

(System meets OSHA regulations.)

Service - Four-wheel, air-actuated, oil-disc brakes are completely sealed and adjustment-free with 2.39 m²/3712 in² total braking surface. Low air pressure, below 414 kPa/4.1 bar/60 psi in either circuit of the brake system, is indicated to the operator by visual (red light and flashing LED) and audible (horn) warnings.

Parking - (System meets SAE J1152 and ISO 3450.) Multiple oil-disc located in transmission case, manually actuated, spring-engaged, air-disengaged. Push the red lever on the transmission control console forward to actuate. This neutralizes the transmission, engages the parking brake and activates the transmission neutral lock to prevent machine movement if engine is started with transmission engaged.

Secondary braking system - Dual circuit air system includes an individual circuit to each tandem for added braking protection. A malfunction in one circuit still leaves the machine with at least half its original braking capacity for fast stops.

In the event of total loss of service brakes, the spring-actuated, nonmodulated parking/secondary brake can be applied to bring the machine to a stop, even if the air supply is interrupted. (Method not recommended for repeated applications.)



Axles

Front - solid-steel, arched bar provides 625 mm/24.6" ground clearance. Oscillates total of 32°.

Front wheel lean angle..... 18° left or right
Rear - full-floating, forged, heat-treated steel.



Tandems

Height x width.....572 x 201 mm/22.52" x 7.90"
Sidewall thickness, outer.....18 mm/.71"
inner.....16 mm/.63"
Drive chain pitch.....51 mm/2"
Wheel axle spacing.....1524 mm/60"

Engine

- Injection nozzles are field replaceable. Six hole tip converts fuel flow to fine spray for complete combustion.
- Individual, scroll-type fuel pumps for each cylinder require no balancing ...maintaining fuel efficiency without periodic adjustment.
- Forged, induction-hardened crankshaft can be reground and reused.
- Caterpillar Remanufactured cylinder heads, unit injector, oil pumps, connecting rods, crankshafts, turbochargers, water pumps and starters are available for fast, economical repairs.

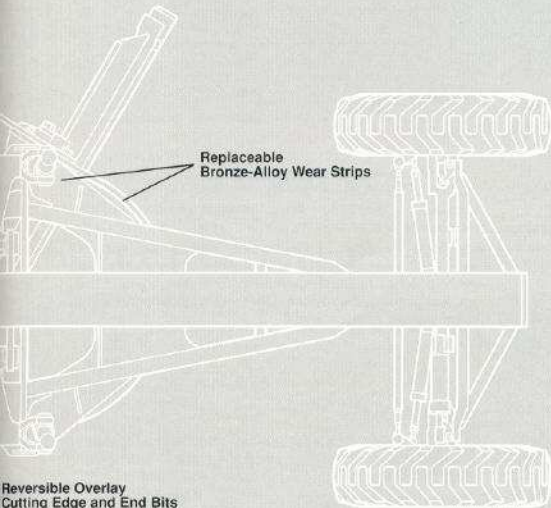

Reversible Overlay
Cutting Edge and End Bits



Total Customer Support

Unmatched in the industry!

- **Parts availability** — Most Cat parts are immediately available off the shelf. Dealer parts availability is backed up by Cat's computer-controlled, emergency search system.
- **Service capability** — Whether in the dealer's fully equipped shop or in the field, you'll get trained servicemen using the latest technology and tooling.
- **Machine management services** — Cat dealers help manage equipment investments with:
 - Effective preventive maintenance programs.
 - Diagnostic programs like Scheduled Oil Sampling and Technical Analysis.
 - Information to make the most cost-effective repair option decisions.
 - Customer meetings, training for operators and mechanics.
- **Exchange components for quick repairs** — Assure maximum, cost-effective uptime.
- **Literature support** — Easy-to-use operation and maintenance guides help you get the full value out of your equipment investment.

FEATURES

Serviceability

Less time spent on maintenance gives you more time on the job.

Outside-Mounted Hydraulic Valves

- Easier to check or service than valves located inside the hydraulic tank.

Electrical Connectors

- Sure-Seal Electrical Connectors provide long service life, resist moisture, corrosion and dirt.

Power Train Components

- Easily accessible for adjustments and major repairs.
- Transmission and final drives can be removed as units without disturbing the engine.
- Diagnostic connector helps troubleshoot electrical problems.

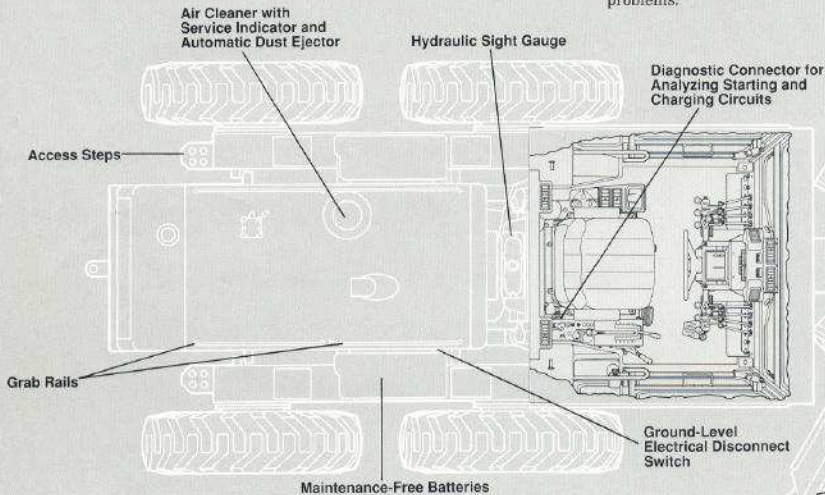

Oil and Fuel Filters

- Disposable, spin-off oil filters are easy to change without allowing contaminants into systems.
- Transmission and hydraulic systems use identical filters, simplify parts stocking.

XT-3 Hydraulic Hose

Cover...Abrasion and weather resistant. Mine Safety and Health Administration (MSHA) Certified.

Cushion...Holds wire in place and eliminates wire rubbing.

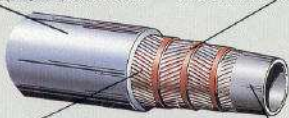

High-strength Wire...Spiral wound for flexibility.

Flexible Inner Liner...Fabric reinforced for strength.



Structure

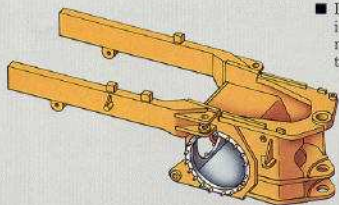

- Differential housing is built into the frame, thus maintaining better alignment than a bolt-on unit.

- Double, tapered roller bearings on the bottom of articulation joint are dependable and maintenance free.

- Box-section rear frame is connected to the case with steel castings.

- Side plates are welded to the top and bottom plates away from the edges, resulting in a flanged box-section, giving a rigid, long-lasting frame.

- The top plate from the bolster to the articulation joint is a single, high-strength steel plate, providing a rigid frame for fine grading.

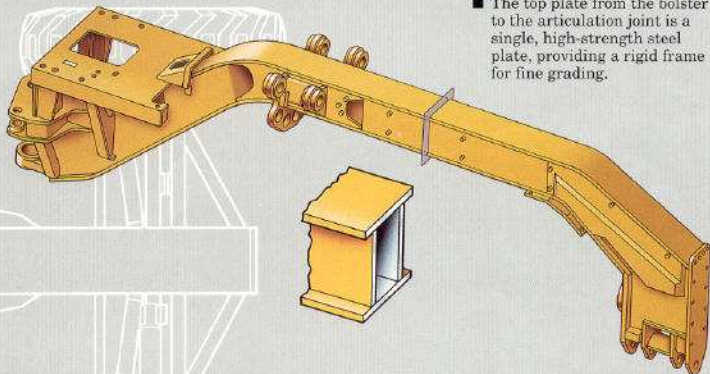

Drawbar/Circle... Built strong and durable for long life.

■ Drawbar

- Features a box-section, A-frame, for high strength.
- Machined to provide accurate adjustment and precision blading.

■ Circle

- One-piece forged circle with induction-hardened, flame-cut teeth.
- Replaceable bronze-alloy wear strips eliminate circle shoe grease fittings and extend wear life.

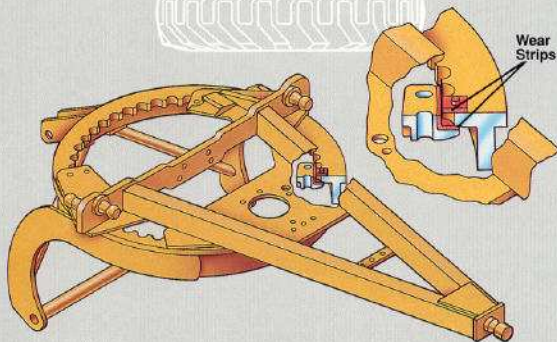

FEATURES

Operator's Station

Designed for sit-down operation the moment you climb aboard. Equipped for convenience, comfort and control — three keys to productivity.

- Excellent visibility to both ends of blade.
- Optional adjustable suspension seat — the most comfortable position for each operator. (Vinyl static adjustable seat provided with canopies.)
- Control console adjusts back and forth for each operator — comfortable sit-down operation, easy entry and exit.
- Blade control levers engage smoothly and crisply.
- Low or high profile, resiliently mounted, sound-suppressed cab for reduced noise and vibration.
- Standard, static adjustable seat with cloth cushions.
- Cab slopes outward toward top to provide spacious working environment.
- Heavy gauge steel column assembly provides a sturdy, durable console.
- Belted steps provide easy, sure-footed access.

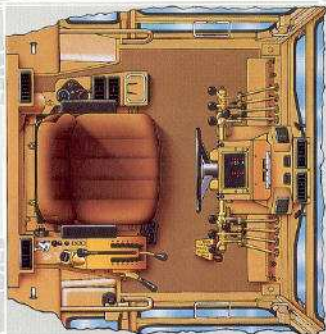

- **Electronic Monitoring System (EMS)** — shows status of important machine systems. Operator concentrates on production instead of watching gauges. Reduces the possibility of catastrophic failures and subsequent costly repairs.
 - Level one — Alternator.
 - Level two — Engine coolant, Hydraulic oil temperature.
 - Level three — Engine oil pressure, Brake pressure.

Total Climate Systems (optional)

- **Air Conditions**...high capacity...cools and freshens hot, humid cab air.
- **Heats**...high capacity...protects against biting cold air in winter operation.
- **Dehumidifies**...removes excess moisture in the air down to 32°F (0°C). On hot, humid days, operator stays fresh and alert.
- **Pressurizes**...keeps air fresh, seals out dust. Approximately one quarter of the total air flow is filtered outside air.
- **Multiple ducting**...allows you to direct the air flow. More ducts, strategically placed, means more uniform temperature throughout the cab.
- Lower cab windows open to provide excellent ventilation.

Load-Sensing Hydraulic System

- Automatically shifts to 2067 kPa/ 21 bar/**300 psi** higher than working pressure.
- Continuously adjusts up to 24 115 kPa/241 bar / **3500 psi** maximum when required.
- Automatically matches flow and pressure requirements (load sensing) for improved fuel economy and precisely matched horsepower demands.

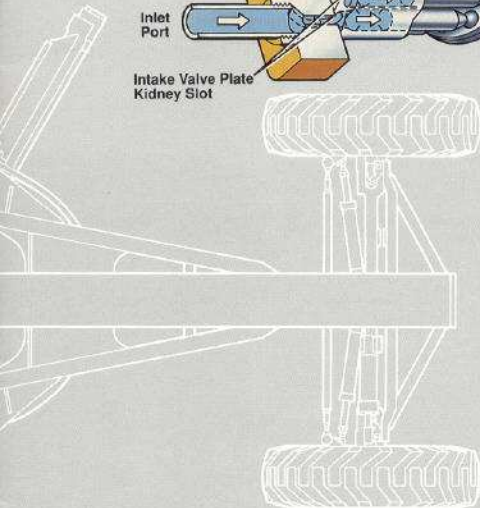
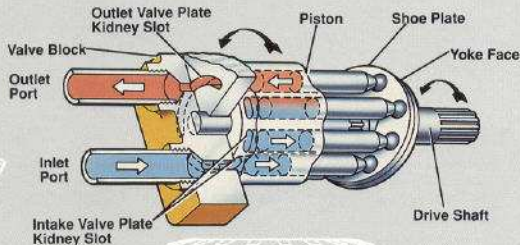

Maneuverability

Three excellent maneuvering modes...for best job match. An important production advantage over conventional motor grader design.

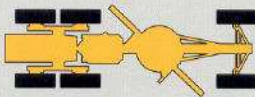

Straight Frame

- Frame centered, front wheels turn for steering.
- Best for long-pass grading.

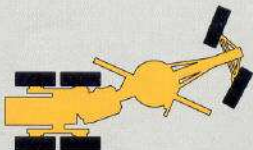

Articulated Turn

- 20° frame articulation.
- 50° front wheel steering angle.
- 18° wheel lean.
- Easier maneuvering in close quarters, quicker turn-around at the end of a pass.

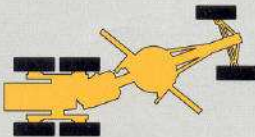

Crab Steering

- Compensates for side drift when turning a windrow.
- Keeps tandems on firm footing when cleaning a wet ditch.
- Increases stability for sideslope work.

FEATURES

Hydraulic System

Fast hydraulic blade controls...precise action at any speed.

Low Effort Control

- Controls can be positioned to fit each operator's need.
- Low lever effort for fingertip response and clustered controls allow a single hand to actuate two or more controls when needed.
- Short throws (38.1 mm/1.5" front to back range) and modulation gives precise hydraulic implement movement.
- O-ring face seals used on all fittings for a "dry machine".
- Separate oil system to protect against contamination from other systems.



Left Blade Lift

Moldboard Side Shift

Blade Tip

Circle Reverse

Drawbar Center Shift

Articulation

Wheel Lean

Right Blade Lift

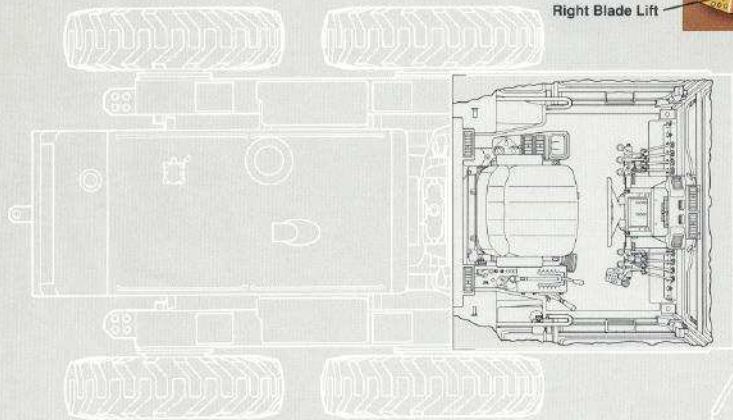
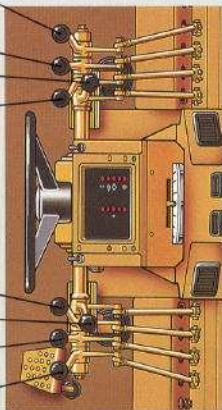

Lock Valves

- In every implement hydraulic circuit...minimizes blade creep and drift.
- Positive hold at each blade setting, for precise finish grading.

Circle drive slip clutch (optional)

- Shock protection for the circle, drawbar assembly, circle drive and moldboard.
- Housed in sturdy cast iron, run in oil and sealed with Duo-Cone seals.

- Rarely needs adjustment. Top access cover permits quick and easy adjustment if required.

Oil Disc Brakes...Protection for man and machine.

- Confident, fade-resistant braking with full air actuation.
- Completely sealed and adjustment free.
- Outboard mounted to prevent drive line stress...easy to service.
- Disc face grooves constantly carry oil between the plates and discs, even when fully applied.
- Each tandem has an independent air circuit, so failure in one line still leaves half braking capacity.

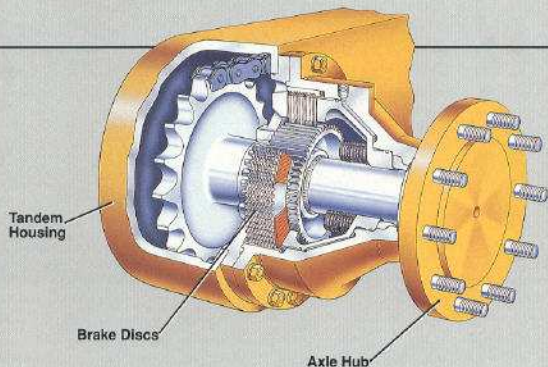

The Competitive Edge

Performance

- Articulated frame — for excellent maneuverability.
- Direct-drive power train — high torque rise Cat diesel engine combined with a direct-drive, power shift transmission gives the feel and efficiency of direct drive. Easy on-the-go shifting, up or down, forward or reverse.

Reliability/Durability

- Frame — flanged box-section main frame resists shocks and vertical flexing.
- Drawbar — box-section, A-frame design for high strength and precision blading.
- One-piece circle — with flame-cut teeth. Induction hardened for long life. Exclusive bronze-alloy wear strips between all circle and drawbar assembly wear surfaces, and moldboard sideshift rails.
- Caterpillar's XT-3 hose — reliable, long life performance.

Maintenance/Repair

- Transmission and final drives can be removed as units without disturbing the engine.
- Sealed, adjustment-free, air-actuated, four-wheel, oil-disc brakes.
- Long lubrication intervals with ground-accessible fittings.
- Easy access to daily service areas for maintenance ease.
- No daily grease fittings.
- Spin-on oil and fuel filters for easy replacement.

Operating Ease

- Adjustable operator's console and steering wheel with short-throw, low-effort controls for ease of operation.
- Optional adjustable suspension seat — the most comfortable position for each operator.
- Good blade visibility.
- Electronic Monitoring System to check all critical functions.
- Low-profile, resiliently-mounted, sound-suppressed cab for reduced noise and vibration.

Total Customer Support System

- Parts availability — most Cat parts on dealer's shelf when you need them — computer-controlled, emergency search system backup.
- Service capability — dealer's shop or fast field service — trained servicemen — latest tooling and technology.
- Machine management services — effective preventive maintenance programs, diagnostic programs (Scheduled Oil Sampling, Technical Analysis), cost effective repair options, customer meetings, operator and mechanic training.
- Exchange components for quick repair — choose remanufactured products or rebuilt components for maximum availability and lower costs.
- Literature support — easy-to-use operation, maintenance guides help you get the maximum value out of your equipment investment.
- Flexible Financing — your dealer can arrange attractive financing on the entire line of Cat equipment. Terms structure to meet your cash flow requirements. See how affordable and easy it is to own Cat equipment.

Custom Machine Products

- In addition to the standard range of optional equipment, special attachments and machine configurations to suit particular customer applications can be made. Contact your Caterpillar dealer for details on matching the Caterpillar product to your special applications.

CATERPILLAR®