

# XDE260

## DOUBLE-AXLE RIGID MINING TRUCK



### RIGID MINING TRUCK

# XDE260

## Product Specifications

OPERATING WEIGHT

**184,000 kg**

RATED POWER

**1864kW / 1900 RPM**

BODY SAE HEAPED 2:1

**148 m<sup>3</sup>**

ENGINE

**CUMMINS QSK60**

# 01

## HIGH PRODUCTIVITY

### High-Performance Engine

- It features original imported high-performance diesel engines with options of MTU or Cummins power assemblies. The MTU16V4000 engine sustains full power up to 5500 meters altitude, while the Cummins engine QSK60 maintains power at altitudes up to 1829 meters. It adheres to China's national off-road stage III and U.S. EPA Tier 2 emission standards, with reliable and powerful performance.
- It produces clean, quiet, and efficient power.
- Engine performance is reliable with advanced technology, convenient for diagnostic troubleshooting, and easy to maintain.



### Wabtec Electric Drive System

- It utilizes the imported Wabtec electric drive system for safe and reliable operation, with a low failure rate and low maintenance costs. This ensures constant power control and stepless speed adjustment, as well as strong traction capability, to maintain maximum production efficiency.
  - Compared to mechanical drive systems, the electric drive system has a simpler structure, uses less fluid for maintenance, requires less time for repair, and has lower maintenance costs.
  - The main generator employs a three-phase AC synchronous generator with a long service life and convenient maintenance.
  - The traction motors use three-phase squirrel cage AC variable frequency induction motors, with mature technology, reliable and durable, and a long lifespan.
- \* Optional XCMG 260 electric drive system available

### Electric Retarder Control System

The XDE260 electric retarder system provides a maximum braking power of 3900HP (2910kW), with continuous braking power at 3700HP (2761kW), meeting the braking requirements of fully loaded continuous downhill travel, thus enhancing operation safety and production efficiency.

### Weighing System

The on-board weighing system is designed for payload data detection and analysis, aiming to optimize the payload and maximize productivity, while reducing the machine's life cycle costs. The on-board weighing system tracks and records the following key manufacturing parameters:

- Payload
- Total number of hauls
- Total weight transported
- Percentage distribution of payload
- Times and distances of unload and full load



☎ 1300 BROOKS (276 657)

@ sales@brooksequipment.com.au

🌐 www.brooksequipment.com.au

**BROOKS**  
EQUIPMENT

# 02

## HIGH RELIABILITY



☎ 1300 BROOKS (276 657)

@ sales@brooksequipment.com.au

🌐 www.brooksequipment.com.au

**BROOKS**  
EQUIPMENT

### Long-Life Frame Design

The frame of the XDE260, adopts advanced CAD and FFEA methods, is verified through dynamic testing of all operating conditions to ensure a structure capable of high payload bearing with superior strength and reliability. A box-section design and manufacturing with high-strength alloy steel plate provide excellent resistance to fatigue, low-temperature impacts, and welding performance. Key high-stress areas are reinforced with 16 cast steel and 2 forged components, aiming for a prospective working life of over 90,000 hours.

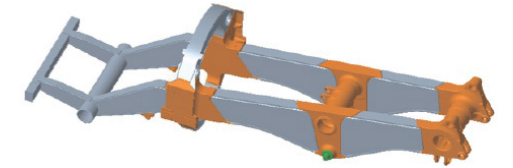

### Simple and Reliable Hydraulic System

The hydraulic system is elegantly simple and dependable, utilizing fewer components to control steering, braking, and lifting functions. A modular design approach allows the hydraulic pump and lift valve components to be mounted on the same support for quick repairs and replacements. Multiple stages of hydraulic oil filters ensure high filtration precision, large contamination capacity, and extended maintenance intervals.



### Robust and Reliable Body Design

Manufactured from high-strength, low-alloy wear-resistant steel plates, the XDE260's body features optimized structures at the hoist cylinder tipping seat and frame hinge support areas for enhancing localized strength and improving fatigue resistance. Utilizing CAE software, the complete structure of the body undergoes simulation analysis for optimization, ensuring its strength and rigidity, and enhancing reliability and durability.

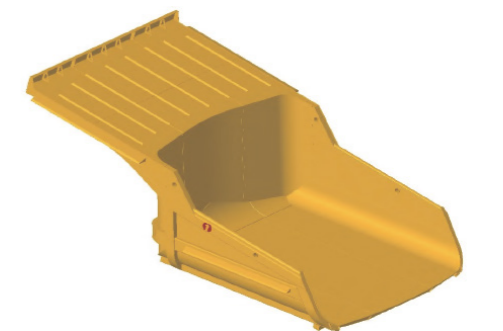

UNLIMITED INNOVATION

# 03

## COMFORTABLE AND SAFE

### Ergonomically Designed Cab

The cab design provides a comfortable and secure operating environment to meet modern mining requirements. It is constructed with ROPS and FOPS structures that conform to ISO 3471 and 3449 standards. The ergonomically interior decoration, component layout, extra large interior space, and integrated touch display screen, all focus on ergonomics. The cab features a climate control system catering to most mining areas. Double layered laminated windows, dual-sealed doors, pressure system for cab, and multi-directional and multi-angle control for air-tightness and noise reduction.

### User-Friendly Display Screen

The XDE260 features a practical and easily readable dashboard, equipped with a CAN-bus LCD instrument cluster, display screen, and functional switches for the driver to monitor truck's status parameters and fault information in the process of driving. The instrument cluster consolidates the engine, hydraulic system, drive system, and weighing system status information, including fault display and equipment information settings.



### Comfortable and Durable Suspension System

The suspension system uses four gas-oil ratio variable nitrogen/oil cylinders to reduce the impact from the transportation road and load, so that the frame service life could be extended. The front suspension has a variable stiffness independent design, and the left and right are symmetrical, ensure wheel alignment and stable, realizing excellent riding comfort. The rear suspension is the longitudinal triangular independent suspension of the swing arm type, which allows the swing of the rear axle housing, and effectively absorb the bending and torsional stresses caused by the harsh road.



### Multi-Directional Adjustable Seat

The driver's operating comfort is the key to safe and efficient production, and the XDE260 is equipped with luxurious air-suspended seats that absorb vibrations and reduce fatigue. The seat is adjustable in multiple directions. It is used in conjunction with a retractable/tiltable steering column to accommodate different driving postures for improving comfort. Seat armrests, safety belts, and cushions are included as accessories.

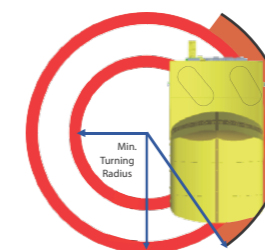

### Reliable and Safe Braking Control

Mature and reliable braking system ensures safe and efficient operation of truck, boosting driver confidence and enabling them to focus on production and transportation tasks. The XDE260 is equipped with superior-performance hydraulic disk brakes on both the front and rear wheels, providing functions for service braking, loading braking, parking braking, and auxiliary braking. Combined with the electric braking function of the electric drivetrain to realize hybrid braking control of the truck, the truck has excellent braking performance at all operating speeds. The braking system includes an accumulator and its parameters are superior to the ISO3450 indicator.

### Agile and Flexible Steering Performance

The XDE260 utilizes an integrated steering mechanism powered by dual-action hydraulic steering cylinders, with an accumulator for emergency steering control that complies with ISO 5010. A turning radius of 14.2 meters, high mobility ensures the high safety of the vehicle in the mine harsh road.



☎ 1300 BROOKS (276 657)

@ sales@brooksequipment.com.au

🌐 www.brooksequipment.com.au

**BROOKS**  
EQUIPMENT

# 04 EASY MAINTENANCE

## Convenient Maintenance Access

The design of the XDE260 takes maintainability into account, allowing for quick and easy servicing. Maintenance ladders are provided on both sides of the front longitudinal beams to offer convenient access for engine inspection and maintenance. The front of the vehicle bumper is equipped with an engine emergency stop switch, a ladder light switch, and fuel quick-fill ports on both sides of the center of the frame, making it easy for maintenance personnel to operate on the ground.

## Concentrated Oil-Filling System

The centralized filling system consists of receivers, dust caps, flanges, and dust respirator, including filling and discharging oil, hydraulic fluid, fuel, grease, and coolant. The centralized filling device is located on the right side of the front frame's longitudinal beam, close to the ground, making it easy to operate.

## Modular design For Easy Assembly and Disassembly

XDE260 whole truck adopts modular design, which is easy to disassemble, install, transport and maintain. In particular, the frame and rear axle adopt an imounted joint bearing seat, which simplifies assembly and disassembly, reduces downtime for maintenance, and enhances truck's availability.



## Full-Automatic Centralized Lubrication System

XDE260 is equipped with full-automatic centralized lubrication system, which fully lubricates 19 articulation points of the key moving parts of the vehicle, saves vehicle maintenance time, improves the quality of vehicle maintenance, and reduces the intensity of vehicle maintenance work. The automatic lubrication system has pressure detection, alarm and lubrication interval programmable control.



## LCD Screen

- The cab's instrument display is used for installation, maintenance, and troubleshooting.
- The main page of the display shows important driving information such as vehicle speed, engine speed, engine water temperature, etc., which makes it easy for the driver to check the status of the whole vehicle.
- Basic troubleshooting no longer requires access to the control cabinet.



☎ 1300 BROOKS (276 657)

@ sales@brooksequipment.com.au

🌐 www.brooksequipment.com.au

**BROOKS**  
EQUIPMENT

# XDE260

## DOUBLE-AXLE RIGID MINING TRUCK

### TECHNICAL PARAMETERS

#### Engine

Model ①	Cummins QSK60
Emission standard	GB20891-2014国三/U.S. EPA Tier2
Fuel	Diesel fuel
Number of cylinders	16
Stroke	4-stroke
Gross power*	1864kW(2500HP)@1900rpm
Net flywheel power**	1754kW(2350HP)@1900rpm
Weight (dry)	8470kg
Model ②	MTU16V4000C23R
Emission standard	GB20891-2014国三/U.S. EPA Tier2
Fuel	Diesel fuel
Number of cylinders	16
Stroke	4-stroke
Gross power*	1865kW(2500HP)@1800rpm
Net flywheel power**	1754kW(2350HP)@1800rpm
Weight (dry)	8300kg

\*Gross Power is the output of the engine as installed in this machine, at governed rpm and with engine manufacturer's approved fuel setting. Accessory losses included are water pump, fuel pump and oil pump.

\*\*Net Flywheel net power is the rated power at the engine flywheel minus the average accessory losses. Accessories include the fan and the alternator, which comply with SAE J1349 standard.

#### Electric Drive System

AC electric drive system	Wabtec Drive System
Drive mode	AC-DC-AC
Alternator	5GTA41
AC electric wheel	5GEB25
Wheel gear reduction ratio	31.875:1
Speed (max.)	64km/h
*Optional	XCMG 260AC Drive System

#### Tires and Rims

Tubeless, radial tires, standard tires*	50/80R57
Flange mounted, five-piece rims	32.00/6.0
Rim rated cold inflation pressure: 758 kPa (110 psi) Typical tire (6) total weight	23184kg
*Tires should meet application requirements for their TKPH/T-MPH tread, compound, inflation pressure, plyrating, or equivalent etc.	

#### Cab

The ROPS/FOPS cab, which aligns with ISO 3471/ISO 3449 (Level II) standards for anti-rollover/anti-falling object protection, offers a spacious space and a wide vision, with all kinds of display instruments, alarms, lighting devices, control switches, radio and relevant devices completely provided, including an adjustable air-suspending damping high-backrest driver seat, a front passenger's seat, a vehicle computer, electric windows, a tilting and telescoping steering wheel, electric windshield wipers, colored glass and an air-conditioning system with both heating and cooling options. The vehicle running data and fault alarm contents are displayed by means of a touch LCD display plus controllable instruments.

#### Suspension

Variable oil/nitrogen suspension cylinder with integrated rebound control	
Max. stroke of front suspension	330mm
Max. stroke of rear suspension	292mm
Max. lateral swing angle of rear axle	±10.3°

#### Frame

The frame is made up of a pair of longitudinal beams and five cross beams, which together form an enclosed structure. Both the longitudinal and cross beams adopt a box-section structure to help eliminate concentrations of bending and cracking stress. The frame is constructed of high-quality, low-alloy, and high-strength steel, with castings used in high-stress areas to increase the frame strength. All critical welds are 100% inspected using ultrasonic testing.

Installation of drive axle	Connected by pin shaft, knuckle bearing and bushing
Lateral positioning of drive axle	Connected by a lateral stability tie rod

#### Body

The body uses high-strength steel for the bottom and side plates with a yield strength greater than 1000 MPa, ensuring a robust structure. It features high-hardness, wear-resistant liners for a longer service life and a single-slope structure for the bottom, providing clean unloading. Safety rope brackets are included as well. Available with heated body.

Bottom plate	Thickness 20mm
Front plate	Thickness 12mm
Side plate	Thickness 10mm
Cap plate	Thickness 5mm
Flat loading	108m <sup>3</sup>
SAE 2:1	148m <sup>3</sup>

\*Customizable according to customer requirements

#### Braking System

The braking system complies with the ISO3450-2011 standard	
Front brake	Brake disc diameter: 1160mm, 4 calipers/disc
Front brake pressure	15MPa
Rear brake	Brake disc diameter: 635 mm, 2 disks/wheel, 1 caliper/disc
Rear brake pressure	10MPa
Auxiliary braking system	When hydraulic system pressure is below a set value, the system is automatically engaged (pressure supplied by accumulator)
Loading brake	Switch activated, with service brakes applied to rear wheels
Parking brake	Spring applied, hydraulic released
Electric retarder	Max. 2910 kW

#### Cooling System

Buffer tube structure radiator, integrated overhead expansion tank, suitable for 5500 meters altitude application pressure cover 14PSI with manual exhaust valve.

Radiator frontal area:	6.47m <sup>2</sup>
------------------------	--------------------

#### Hydraulic System

Variable plunger pump provides steering fluid, with load-sensing, flow amplifying power steering system; steering wheel requires low effort to manipulate, with quick response, high precision, and smooth operation. The accumulator provides emergency steering fluid source.

Steering	Oil suction filter 250µm
Turning diameter (SAE)	28.4m
Filter	Oil return filter 10µm
	Lifting and steering high-pressure filter 10µm
Brake components cabinet	Located on the deck behind the cab for easy diagnostics
Lifting	Two 3-stage, double-acting external cylinders with built-in cushion valves
Lifting time	
- Lifting (load)	28s
- Lowering (high idle speed)	18s
- Lowering (low idle speed)	25s
Pump	Double-pump direct drive
	Gear pump in series connection
- Lifting pump	Flow 819L/min@1900rpm
	Max. working pressure: 18mPa
	Variable plunger pump
- Steering pump	Flow 275L/min@1900rpm
	Max. working pressure: 24.5mPa
System relief pressure	
- Lifting system	18MPa
- Steering system	27.5MPa
Quick interface helps offer power to the faulty truck and for system diagnosis	

#### Electrical System

6 maintenance-free 975CCA, 12V batteries arranged in series/parallel, mounted on the bumper with a disconnect switch

Alternator	24V/250A
Lighting equipment	24V
Starter motor	2Units/24V

#### Oil Filling Capacity

Cooling system	CUM 750L/MTU 800L
Crankcase*	CUM 260L/MTU 280L
Hydraulic system	960L
Front wheel (each)	40L
Motorized wheel (each)	38L
Fuel tank	4500L

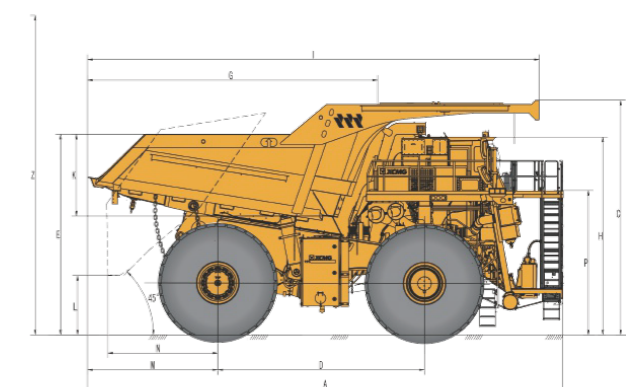

C:7205	H:6074	P:4310	I:13874
G:8838	R:870	D:6350	A:14595
N:3360	M:4000	K:2527	L:1839
E:6158	Z:14454		

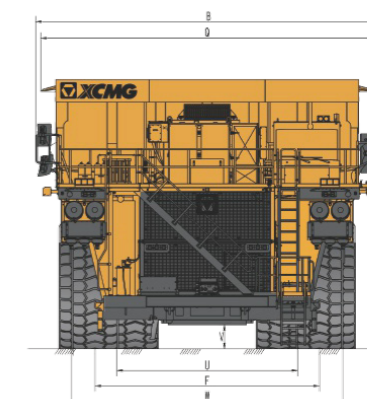

B:9104	Q:8923	V:640
U:4764	F:6020	W:7194

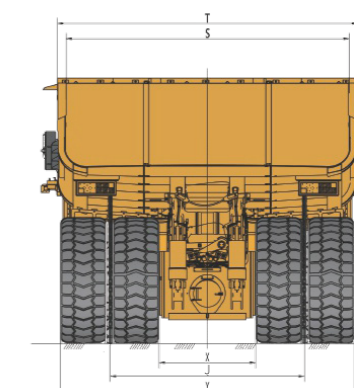

T:8130	S:7650	X:2611
J:5244	Y:7961	

\*Standard body, flat loading: 108m<sup>3</sup>  
SAE Heaped 2:1 148m<sup>3</sup>  
\*Tire 50/80R57



## Performance Curve

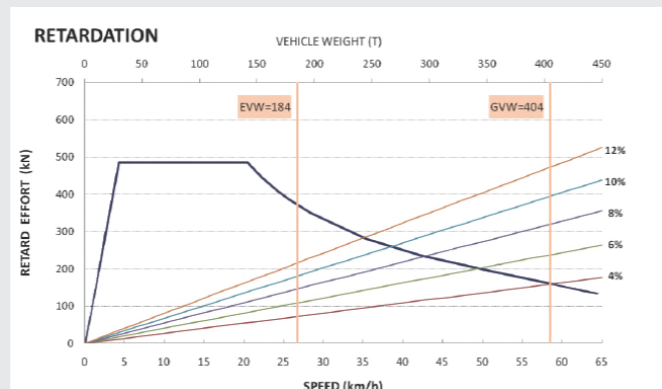
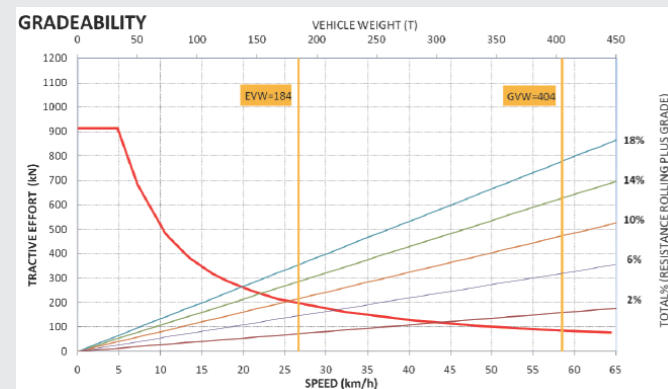

### Empty Vehicle Weight (EVW)

Front axle distribution (51%)	93840 kg	206882 lbs
Rear axle distribution (49%)	90160 kg	198769 lbs
Total EVW	184000 kg	405651 lbs

### Gross Vehicle Weight (GVW)

Front axle distribution (33%)	133320 kg	293920 lbs
Rear axle distribution (67%)	270680 kg	596747 lbs
Nominal GVW	404000 kg	890667 lbs

### Load Capacity

Payload	220000 kg	485017 lbs
---------	-----------	------------

\* The empty vehicle weight (EVW) includes the standard chassis, standard body, attachments, lubricating oil, fuel, and operator.

\*\* Rated payload includes all optional attachments.

## USE OF EQUIPMENT AND PRECAUTIONS

### XCMG Mining Truck Loading Specifications

The loading specifications define the loading guidelines and restrictions for XCMG mining trucks:

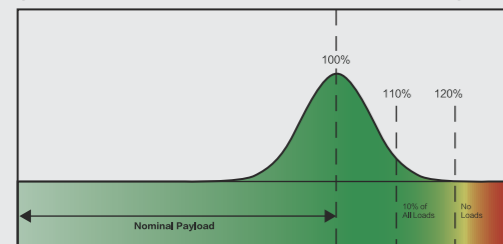

- Gross vehicle weight (GVW) includes the chassis, body, tires, attachments, lubricants, fuel, operator, payload, and any excess material accumulation.
- The monthly average payload should not exceed the truck's rated payload.
- Actual payload ≤ 110% of rated payload, the proportion shall be no less than 90%.
- 110% of rated payload ≤ actual payload ≤ 120% of rated payload; the proportion shall be no more than 10%.
- In any case, actual payload ≥ 120% of rated payload.

\*Rated payload includes all optional accessories.

#### Notes:

1. The graphics and information in this brochure reflect the technical characteristics and configuration standards of some models at the time and are based on standard usage case testing. The above-mentioned data and information are for reference only; please take the actual object as final.
2. This brochure is for reference only and is not contractually binding. For detailed information, please contact your local XCMG Mining Machinery dealer.
3. Without authorization from Xuzhou XCMG Mining Machinery Co., Ltd. reserves the right to interpret and modify this brochure.



### Standard Configuration

- Self-cleaning air filter
- Alternator (24V/250A)
- Automatic lubrication system, liquid level indicator
- Backup alarm
- Battery – 6 pcs., 975CCA
- Battery charging/jump-start connector
- Body position limiting device
- Body safety rope
- Front brake: dry disk brake
- Rear brake: dry disk brake
- Electric control cabinet
- Electric retarder cruise system
- Electric start
- Hydraulic high-pressure filter
- Mirror:
  - Left: flat mirror, with heating
  - Right: convex mirror, with heating
- Mudguard
- Muffler – mounted on the deck
- Power supply, 24V and 12V DC
- Quick coupling (for lifting and diagnosis)
- Radiator liquid level indicator
- Detachable power assembly (engine, alternator) Electric retarder
- Fan clutch

### Operating Environment and Control

- Full hydraulic service brake, with automatic engage function
- Power switch
- Brake and traction interlock
- 24V circuit breaker
- Boarding ladder
- Dynamic deceleration
- Lift and towing interlock system
- Horn (electric-front)
- Integral ROPS/FOPS (Benchmark II) driver's cab
- Parking brake with warning lamp and speed application protection
- Power steering system with automatic auxiliary steering
- Deck handrail
- Transmission shaft shield
- Radiator fan cover
- Seat belt: standard three-point type Anti-skid passage
- Engine access platform, left/right

### Lighting Equipment

- Backup light – 2 LED units mounted at the rear
- Backup light – 2 LED units mounted on the left and right sides of the deck
- Brake and deceleration lamp LED mounted on top of cab
- Turn/marker lamp (8)(LED)
- Dynamic deceleration lamp, rear (2)(LED)
- Engine compartment inspection lamp (4)(LED)
- Axle inspection lamp (LED)
- Fog lamp (2)(LED)
- Headlamp (8)(LED)
- Ladder lamp and platform lamp (LED)
- Brake lamp, rear (2)(LED)

### Standard Luxury Cab

- Ac drive interface display screen
- Air conditioner R-134A
- AMFM radio, equipped with USB and MP3
- HEPA rated supercharger
- Roof light
- Multi-purpose driver's display panel
  - Light status
  - Engine hours, oil pressure, water temperature, engine oil temperature, fuel level
- Multi-purpose driver's display panel
  - Mileage, speed and duty load
  - Ambient temperature and time
  - System voltage
  - Engine red light and yellow light alarm
  - Low system voltage
  - Low engine coolant level
  - Gear position indicator
  - Excitation indicator
  - Parking brake indicator, service braking indicator, electric braking

### Standard Luxury Cab

- Floor mat (double baffle)
- Fuel gauge of the cab
- Low fuel level indicator lamp and buzzer
- Instrument (with backlight)
- Headlamp switch
- Heater and defroster (heavy duty)
- Radiator switch
- High beam light selector and indicator
- Horn (steering wheel center)
- Weighing system display
- Driver's seat, adjustable, with air suspension, waist support and armrest
- panel lighting (adjustable)
- Co-driver's seat
- Power window
- Positive pressure cab
- Electric retarder brake pedal
- Hydraulic brake pedal
- Sun visor (adjustable)
- Telescoping/tilting adjustable steering column
- Voltmeter (battery output)
- Windshield glass (tinted safety glass)
- Windshield wiper (double) and washer (electric)

### Factory Optional Equipment

- Note: Optional devices may change working weight.
- 1000L/min Quick filling fuel system (on fuel tank and at hydraulic oil tank side)
- Amber signal lamp
- Antifreeze solution: below -40°C
- Body, standard and customized heating
- Anti-wear plate of body
- Tires
- AGCCS System
- Tire Temperature and Pressure Monitoring System
- Rock beater bar/chain
- Cryogenic suspension system: front and rear
- Electric heaters (engine coolant, engine oil, hydraulic oil, fuel)
- Liquid fuel heater (engine coolant)
- Centralized quick fill – left or right side (coolant, engine oil, hydraulic oil, grease)
- Mudguard – fuel and hydraulic oil tanks
- Seven pieces quick release rims
- XCMG-360 panoramic video system
- Weighing Display – right and left side
- Suspension Charging Kit
- Toolbox
- Cab tinted glass
- Hill start assist
- Oversized signal light at rear of body
- Protective plate on the front of the body (ramp ladder protection)
- One-key export of weighing data
- Low level fog lamps
- High-end seat (ISRI seat)
- Rear axle door safety protection
- Brake test function

### Localized Optional Equipment

- Engine Emergency Stop Button – Ground
- Battery Charge/Jumper Start Connector
- Lockable starter motor, power disconnect switch
- Automatic Fire Extinguishing System
- 2 Fire Extinguishers
- Emergency stop switch
- HEPA pressurized filtration
- Delayed engine shutdown
- Power backup jack
- Canvas seat cover
- Tire block
- Intercom
- Attention:

1. The use of bodies supplied by XCMG is mandatory. Bodies designed by XCMG and manufactured locally are recommended. It is not recommended to use bodies provided by third party organizations.
2. Tire temperature and pressure function is used in conjunction with tires.