

BROOKS
EQUIPMENT



XD120

VIBRATORY ROLLER



VIBRATORY ROLLER

DX120

Product Specifications

OPERATING WEIGHT

2,700 kg

RATED POWER

33 HP

DRUM WIDTH

1,200 MM

ENGINE

KUBOTA

PERFORMANCE, RELIABILITY & VALUE

KUBOTA ENGINE

Featuring a choice of 2 engines, the Tier 3 Kubota D1703 or the D1803-CR-E5B, 33 HP, 24.6 kW water-cooled, 3 cylinder engine with high power reserve, low fuel consumption and low noise emission.

HEAVY DUTY DRUM

Inner-cylinder drum chamber is simple and robust for excellent performance, long lifetime and exceptionally high reliability.

COMPACTION

The XD120 has a large diameter drum with two vibration frequencies available, also included is pressurised, interval water spray help the operator get the job done quicker with less tools.

PREMIUM GRADEABILITY

Proportional ASC closed loop hydraulic drive system composed of a variable displacement pump, plus a constant motor. Drum selection is made easy with a switch for front, rear or both.

MANOEUVRABILITY

The XD120 features high transport speed, narrow turning radius and high level gradability, made possible by the closed loop hydraulic propel system.

SAFETY

Safety features of the XD120 include e-stop switch, seat occupation switch and seat belt, helping make the work area. The battery is fitted with an isolator under the hood.

Designed to perform...



☎ 1300 BROOKS (276 657)
@ sales@brooksequipment.com.au
🌐 www.brooksequipment.com.au

BROOKS
EQUIPMENT

COMFORTABLE

Ergonomic setup with comfortable seat, foldable ROPS, multifunction travel control lever, plus easy access to vibration control, horn and spray override.

EFFICIENT MAINTENANCE

Engine hood tilts forward easily and extensively for better access to service and maintenance areas and all fundamental componentry.

EXCELLENT VISIBILITY

The seat position provides the operator excellent drum edge visibility, as well as an easy view of the rear drum. Plus the LED worklights allow better visibility in low light situations.

GLOBAL DOMINANCE

XCMG is the World's 3rd largest construction machinery manufacturer, with branches dealers and service agents throughout Australia.

RELIABILITY & TRUST

XCMG's key focus is the complete satisfaction and success of every machine owner - making your business as profitable as possible.

UNMATCHED SUPPORT

Product experts at your local dealer provide exceptional support throughout your machine's lifetime: operation, maintenance and service from the delivery date through to its last day on the job.



...built to last.



☎ 1300 BROOKS (276 657)
@ sales@brooksequipment.com.au
🌐 www.brooksequipment.com.au



*Easy everyday
maintenance access*



*Comfortable seat, seat
belt, wheel and joystick
controls.*



☎ 1300 BROOKS (276 657)
@ sales@brooksequipment.com.au
🌐 www.brooksequipment.com.au

BROOKS
EQUIPMENT

*Pressurised water
sprayers*

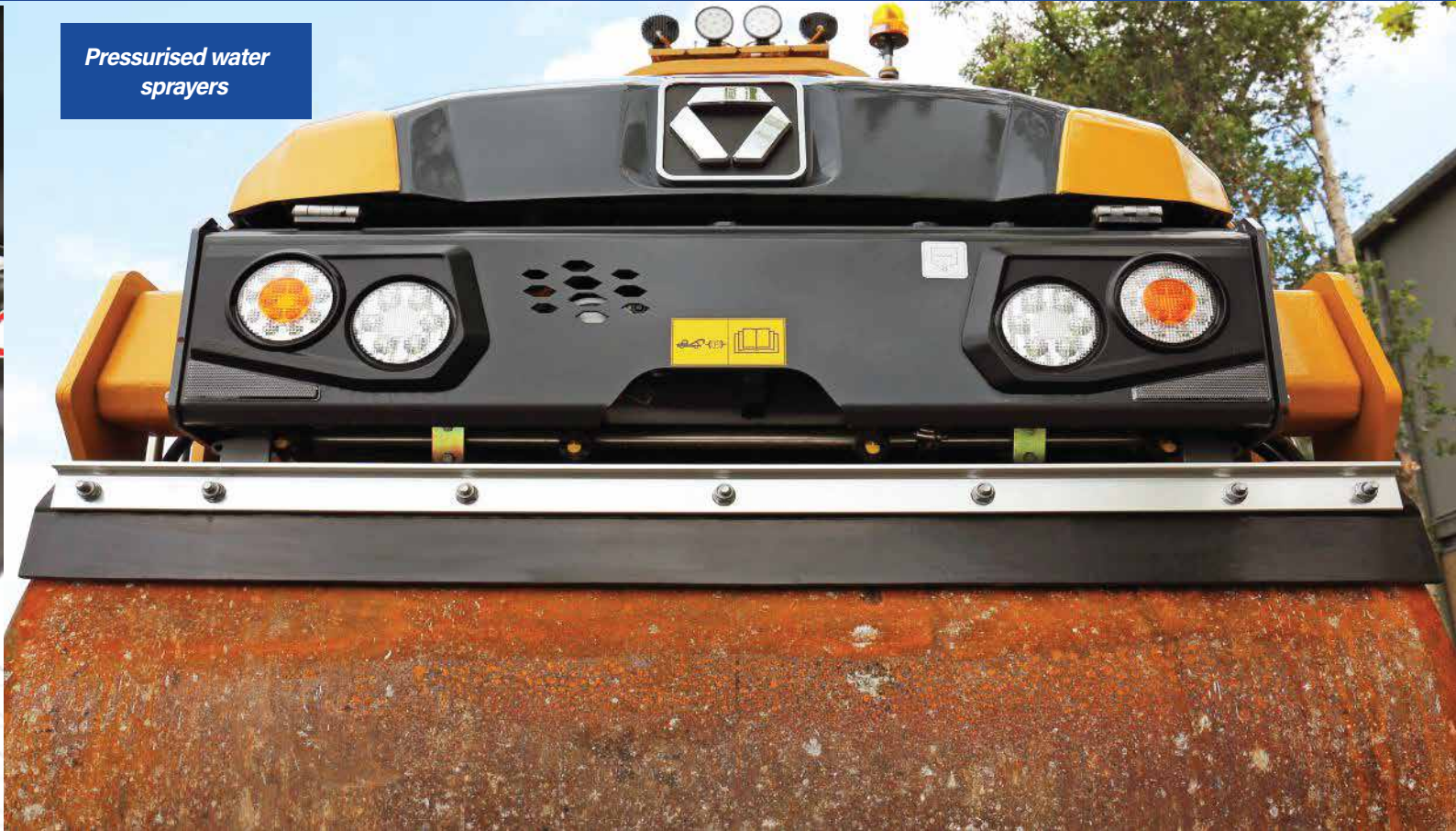

*Heavy duty drum for
exceptional durability*



☎ 1300 BROOKS (276 657)
@ sales@brooksequipment.com.au
🌐 www.brooksequipment.com.au

BROOKS
EQUIPMENT

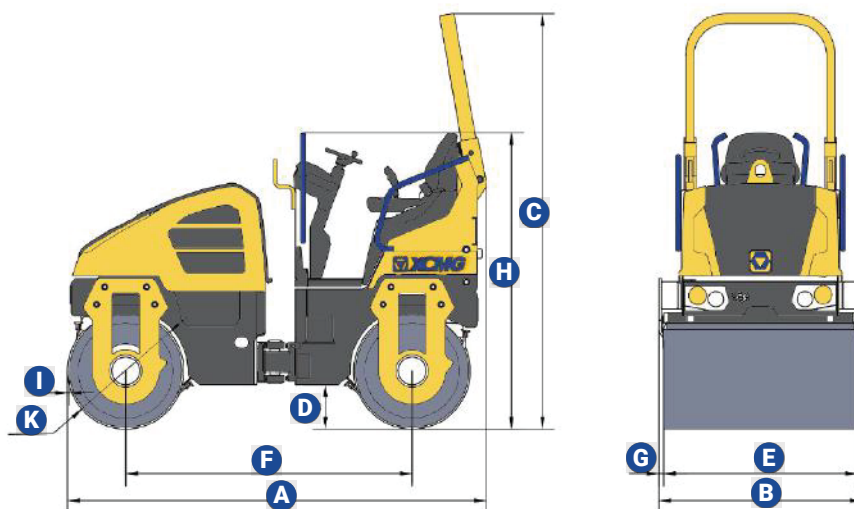

Dimensions (mm)	A	B	C	D	E	F	G	H	I	K
XD120	2565	1286	2575	275	1200	1773	42	1845	11	720

Item	Content	Unit	XD120
Parameters	Operating Weight:	kg	2700
	Static Load Front Drum:	N/cm	110
	Static Load Rear Drum:	N/cm	110
	Amplitude:	mm	0, 5
	Frequency:	Hz	63/67
	Vibration Force:	kN	36/41
	Drum Dimensions:	mm	720x1200
Propel Performance	Speed:	km/h	0-10
	Gradeability:	%	30
	Minimum Turning Radius - Inner:	mm	2250
	Minimum Turning Radius - Outer:	mm	3450
	Oscillation Angle:	°	±8
Engine Specs	Engine Manufacturer:		Kubota
	Type:		D1803-CR-E5B or D1703
	Cooling:		Water
	Emission Stage:		Tier 3 or Tier 5
	Number of Cylinder:		3
	Performance I30 14390:	kW	24
	Performance SAE J 1995:	hp	33
	Rated Engine Speed:	min-1	2400

