

# KOMATSU®

## WA320-5

**NET HORSEPOWER**  
124 kW **166 HP** @ 2000 rpm

**OPERATING WEIGHT**  
13880 – 14214 kg  
**30,600 – 31,337 lb**

**BUCKET CAPACITY**  
2.3 – 3.2 m<sup>3</sup> **3.0 – 4.2 yd<sup>3</sup>**

**WA**  
**320**

W  
H  
E  
E  
L  
L  
O  
A  
D  
E  
R



Photos may include optional equipment.

# WALK-AROUND

***Komatsu-integrated design*** offers the best value, reliability, and versatility. Hydraulics, powertrain, frame, and all other major components are engineered by Komatsu. You get a machine whose components are designed to work together for higher production, greater reliability, and more versatility.

***Expanded main monitor*** and troubleshooting display.

***Reduced operator noise*** to 70 dB(A).

***Larger cab*** with new layout design.

***New tilt*** steering column.

***4-Piece*** sealing with buffer ring in hydraulic cylinders.

***Multi-function mono lever*** with integrated F/R switch (optional).



***Large breakout force.***

***Extended service intervals.***

***Maintenance-free*** fully hydraulic wet multi-disc service and mechanical wet multi-disc parking brakes.

***Electronically controlled Hydrostatic Transmission (HST)*** with variable shift control system.

***Traction control system.***

**NET HORSEPOWER**  
124 kW 166 HP @ 2000 rpm

**OPERATING WEIGHT**  
13880 - 14214 kg  
30,600 - 31,337 lb

**BUCKET CAPACITY**  
2.3 - 3.2 m<sup>3</sup>  
3.0 - 4.2 yd<sup>3</sup>

A powerful and efficient **SAA6D102E-2 Komatsu engine** is Tier 2 EPA and EU emissions certified.

**Full side opening**  
gull-wing engine doors.

**Radial sealed**  
air cleaner.

**Sealed DT**  
**electrical connectors.**

**Swing-out hydraulic**  
**radiator fan.**

**Side-by-side type coolers**  
for easy access and cleaning.



**Overrun protection system.**

**Ground level servicing**  
and fluid checks.

**Extremely low**  
**fuel consumption.**

Photos may include optional equipment.

**Flat face "O-Ring" hydraulic seals**  
for extended life.

**Staircase-type steps**  
with large rear-hinged doors.

## PRODUCTIVITY FEATURES

### High Productivity and Low Fuel Consumption

#### Powerful Engine

A powerful SAA6D102E-2 turbocharged air-to-air aftercooled diesel engine provides an output of 124 kW **166 HP** for the WA320-5. This engine is Tier 2 EPA and EU emissions certified without sacrificing power or machine productivity.

#### Low Fuel Consumption

The fuel consumption is reduced up to 15% due to the high-torque engine and Hydrostatic Transmission (HST) with maximum efficiency in the low-speed range.

#### Electronically-Controlled HST Using a 1-Pump, 2-Motor System

- The 1-pump, 2-motor system allows for high-efficiency and high tractive effort. Engine power is transmitted hydraulically to a transfer case, then manually out to the differentials and out to the four driving wheels.
- HST provides quick travel response and aggressive drive into the pile. The variable displacement system automatically adjusts to the tractive effort demand to provide maximum power and efficiency.
- Full auto-shifting eliminates any gear shifting and kick-down operation to allow the operator to concentrate on digging and loading.
- When high drive torque is needed for digging, climbing or initiating movement, the pump feeds both motors. This combination makes the loader very aggressive and quick.
- Under deceleration, the HST system acts as a dynamic brake on the mechanical drive system. The dynamic brake can hold the loader in position on most workable slopes. This can be an advantage in stockpiling and ramp loading.
- As the machine moves and gains ground speed, the torque demand decreases and the low speed motor is effectively removed from the drive system by a clutch. At this point, the flow is going to the high-speed motor and the low-speed motor is not causing a drag on the system.
- An inching pedal provides excellent simultaneous control of travel and equipment hydraulic speeds. By depressing the inching pedal, drive pump flow to the motors will decrease, reducing ground speed and allowing the operator to use the accelerator to increase flow to the equipment hydraulics. Depressing the inching pedal further will activate the service brakes.

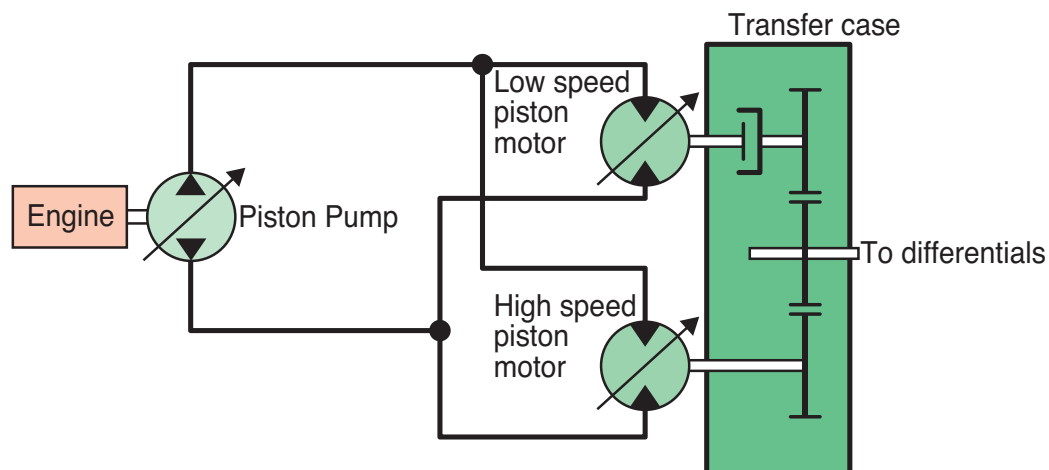

**Electronically-Controlled HST with Variable Shift Control System**

The operator can choose from four speed settings by dialing the speed range selector switch.

For V-cycles, the operator can set the speed control switch to 1 or 2, which provides aggressive digging, quick response and fast hydraulics. For load and carry, select 3 or 4 which still provides aggressive digging but with much faster travel speed.



The variable shift switch allows the operator to adjust the machine speed in confined V-loading applications. When in 1, the operator can adjust travel speed using the variable shift control

switch to match machine speed and hydraulics to the travel distance. This feature will also be an advantage when powering a broom.

**Traction Control System**

The traction control system reduces tire slippage in limited traction situations (such as sandy or wet surface operations). Placing the traction control switch in the "ON" position automatically reduces tire slippage by limiting the maximum amount of tractive effort to 50%. Traction control will be an advantage in certain applications such as transfer stations where the loader may be working on slippery concrete. The traction control operates in 2nd, 3rd and 4th speed.

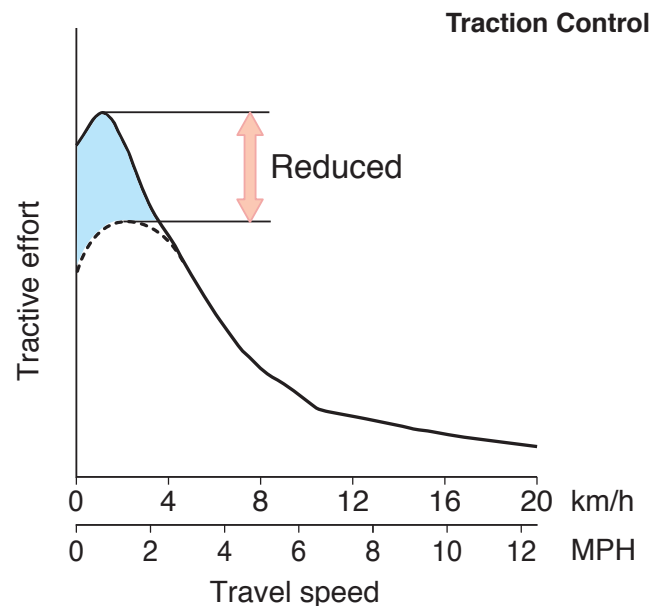
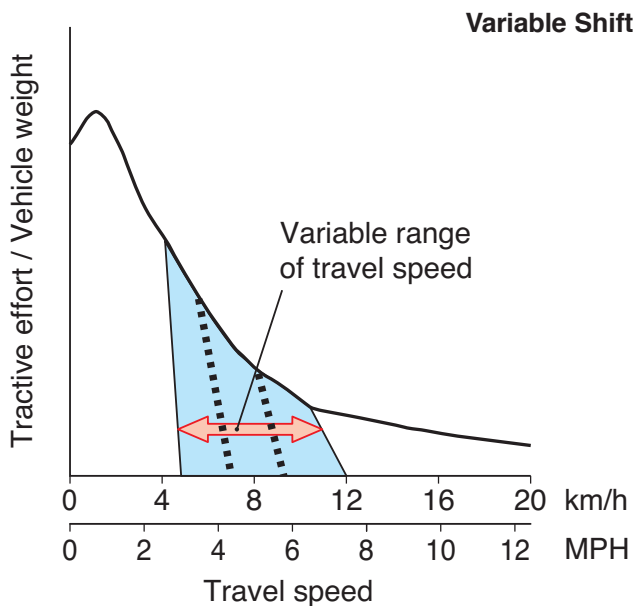

## INCREASED RELIABILITY AND SERVICEABILITY

### Main Monitor — Equipment Management Monitoring System (EMMS)

Komatsu's new main monitor keeps the operator informed of all machine functions at a glance. The monitor is located behind the steering wheel and displays 28 different machine functions including fluid/filter change intervals and troubleshooting memory display functions. The main gauges are analog type for easy viewing and other functions utilize light symbols or LCD readouts.



### Swing-Out Cooling Fan

The new Komatsu cooling system is isolated from the engine to provide more efficient cooling and low noise. The swing-out hydraulic fan allows the operator to quickly clean out the cooling system.



The radiator, air-to-air cooler and oil cooler are mounted side-by-side for more efficient cooling and easy cleaning. A fully-opening, gas spring assisted rear grill gives the operator excellent access to the swing-out fan and coolers.

### Full Side-Opening Gull-Wing Engine Doors

Ground level engine service and daily service checks are made easy with the gas spring assisted full side opening gull-wing doors.



### Extended Service Interval

Extended engine oil service interval:

250 H → 500 H

Extended drive shaft greasing interval:

1,000 H → 4,000 H



### Overrun Prevention System

When the machine descends a slope of six degrees or less, maximum travel speed is automatically restricted to approximately 38 km/h **24 MPH**, for protection against damage of power train components and brakes by sensing the travel speed and controlling the discharge amount of the HST pump and motor. When the machine descends a steep slope and the travel speed reaches 36 km/h **24 MPH**, the caution lamp lights up to inform the operator to reduce the travel speed.

Note: When the machine descends a steep slope, the use of the service brake is necessary to limit travel speed.

**Fully Hydraulic Wet Multi-Disc Service Brakes**

The dual wet disc brakes at each wheel are fully sealed and adjustment free to reduce contamination, wear and maintenance. The result is lower maintenance costs and higher reliability.

Added dependability is designed into the braking system by the use of two independent hydraulic circuits, providing hydraulic backup should one of the circuits fail.

If the brake oil pressure drops, the warning lamp flashes and the warning buzzer sounds intermittently.

The parking brake is also wet multi-disc (it is fully sealed and adjustment free), acting on the output shafts of the transfer case. The parking brake is mechanically controlled by a lever in the cab.

**Parking Brake**

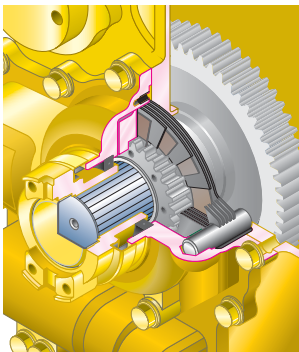

**Service Brakes**

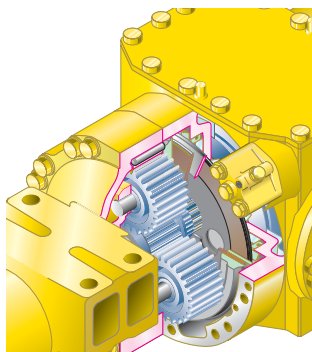

**High-Rigidity Frames**

The front and rear frames along with the loader linkage have high rigidity to withstand repeated twisting and bending loads to the loader body and linkage. Both the upper and lower center pivot bearings use tapered roller bearings for increased durability. The structure is similar to those of large sized loaders and the reinforced loader linkage ensures high strength.



**Flat Face-to-Face O-Ring Seals**

Flat face-to-face O-ring seals are used to securely seal all hydraulic hose connections and to prevent oil leakage.

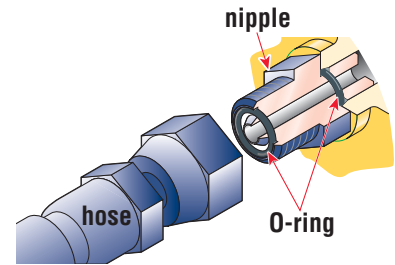

**Cylinder Buffer Rings**

Buffer rings are installed to the head-side of the hydraulic cylinders to lower the load on the rod seals, prolonging cylinder life by 30% and maximizing overall reliability.

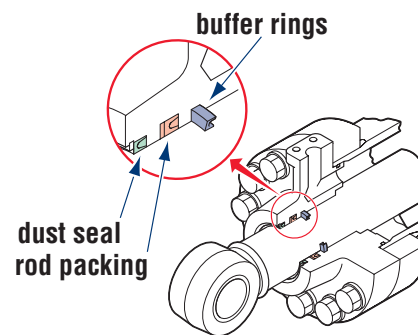

**Cathion Electrodeposition Primer Paint/Powder Coating Final Paint**

Cathion electrodeposition paint is applied as a primer paint and powder coating is applied as a topcoat to the exterior metal sheet parts. This process results in a durable rust-free machine, even in the most severe environments. Some external parts are made of plastic to provide long life and high impact resistance.

**Sealed DT Connectors**

Main harnesses and controller connectors are equipped with sealed DT connectors providing high reliability and dust and corrosion resistance.

**Komatsu Powertrain Components**

Komatsu manufactures the engine, transfer case, and differentials on this wheel loader. Komatsu loaders are manufactured with an integrated production system under a strict quality control system.

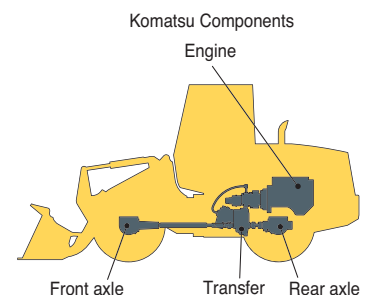

## OPERATOR COMFORT

### New Cab Layout

Komatsu's new cab layout provides the operator with a roomy, quiet and efficient work environment. The low noise level inside the cab leads the industry at 70 dB(A) and loader controls are ergonomically designed to reduce operator fatigue and increase productivity.

### Two Door Walk-Through Cab

Entry and exit into the new Komatsu cab starts with sloped staircase type steps and large diameter handrails. The large cab doors are rear-hinged to open 130 degrees offering easy entry/exit and will not hamper visibility when operating the machine with the doors latched open. A wide pillar-less flat glass windshield provides for excellent visibility. The wiper arm covers a large area to provide great visibility even on rainy days.



### Low-Noise Design

Operator noise: 70 dB(A)

Dynamic noise (outside): 104 dB(A)

The large cab is mounted with Komatsu's unique ROPS/FOPS viscous mounts. The low-noise engine, hydraulically driven fan, and hydraulic pumps are mounted with rubber cushions, and the cab sealing is improved to provide a quiet, low-vibration, and comfortable operating environment. Pressurization in the cab keeps dirt out further enhancing the operator's comfort.

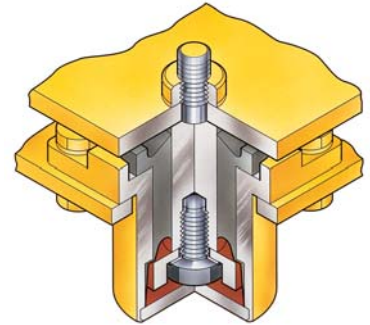

### Electronically Controlled Directional Lever

The solid state electronic transmission shift control provides easy directional changes. The steering column mounted control lever can be operated without removing the operator's hand from the steering wheel, allowing improved comfort and control. The operator can use either the transmission directional control lever on the steering column or the transmission forward and reverse switch on the Multi-function Loader Control Lever (optional).





### Finger Tip Control Levers

Komatsu now offers new finger tip operated hydraulic control levers. This feature matches well with the pilot pressure controlled hydraulics to reduce operator fatigue, improve fine work equipment control and increase overall productivity. The adjustable wrist rest provides the operator with a variety of comfortable operating positions.

### Tilttable Steering Column

The operator can tilt the steering column to allow maximum comfort and control. The two-spoke steering wheel allows maximum visibility of the monitor panel and forward work environment.

### Comforts of Home

The large cab allows room for a large lunch box holder, a variety of cup holders and a hot/cold box storage area. Optional air conditioning and the optional AM/FM cassette system create a comfortable and controlled work environment.

### Multi-Function Loader Control Lever With Forward & Reverse Switch (Optional)

A new optional multi-function control lever integrated with forward and reverse switch allows the operator to easily operate the work equipment, to reduce operator fatigue and to increase controllability.





**DIMENSIONS**

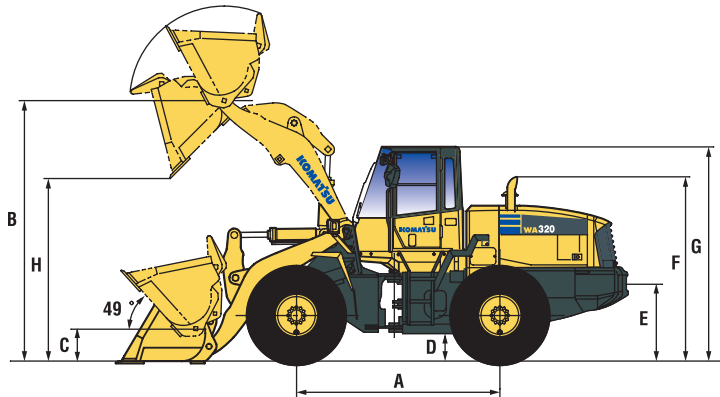

Tread	2050 mm	<b>6'9"</b>
Width over tires	2585 mm	<b>8'6"</b>
A Wheelbase	3030 mm	<b>9'11"</b>
B Hinge pin height at Max. height:	Standard Boom	3905 mm <b>12'10"</b>
	High Lift Boom	4545 mm <b>14'11"</b>
C Hinge pin height at carry position:	Standard Boom	390 mm <b>1'3"</b>
	High Lift Boom	641 mm <b>2'1"</b>
D Ground clearance	425 mm	<b>1'5"</b>
E Hitch height	1095 mm	<b>3'7"</b>
F Overall height, top of stack	2775 mm	<b>9'1"</b>
G Overall height ROPS cab	3200 mm	<b>10'6"</b>
H See Dumping Clearance Below		

Measured with 20.5-25-12PR (L2) tires

Bucket		Stockpile Bucket With Bolt-on Cutting Edge		Excavating Bucket With Bolt-on Cutting Edge		Light Material Bucket With Bolt-on Cutting Edge		High Lift Boom Excavating Bucket With Bolt-on Cutting Edge	
Bucket Capacity	Heaped	2.8 m <sup>3</sup>	<b>3.7 yd<sup>3</sup></b>	2.3 m <sup>3</sup>	<b>3.0 yd<sup>3</sup></b>	3.2 m <sup>3</sup>	<b>4.2 yd<sup>3</sup></b>	2.3 m <sup>3</sup>	<b>3.0 yd<sup>3</sup></b>
	Struck	2.4 m <sup>3</sup>	<b>3.1 yd<sup>3</sup></b>	2.0 m <sup>3</sup>	<b>2.6 yd<sup>3</sup></b>	2.8 m <sup>3</sup>	<b>3.7 yd<sup>3</sup></b>	2.0 m <sup>3</sup>	<b>2.6 yd<sup>3</sup></b>
Bucket Width		2740 mm	<b>9'0"</b>	2740 mm	<b>9'0"</b>	2740 mm	<b>9'0"</b>	2740 mm	<b>9'0"</b>
Bucket Weight		1240 kg	<b>2,734 lb</b>	1330 kg	<b>2,932 lb</b>	1430 kg	<b>3,153 lb</b>	1330 kg	<b>2,932 lb</b>
Static Tipping Load	Straight	12200 kg	<b>26,896 lb</b>	12110 kg	<b>26,698 lb</b>	12010 kg	<b>26,478 lb</b>	9928 kg	<b>21,888 lb</b>
	40° full turn	10610 kg	<b>23,391 lb</b>	10530 kg	<b>23,215 lb</b>	10440 kg	<b>23,016 lb</b>	8637 kg	<b>19,041 lb</b>
Dumping Clearance, maximum height and 45° dump angle		2850 mm	<b>9'4"</b>	2995 mm	<b>9'8"</b>	2715 mm	<b>8'11"</b>	3596 mm	<b>11'10"</b>
Reach at 2130 mm 7' 45° dump angle		1570 mm	<b>5'2"</b>	1675 mm	<b>5'6"</b>	1435 mm	<b>4'8"</b>	2081 mm	<b>6'10"</b>
Reach at maximum height and 45° dump angle (H)		1035 mm	<b>3'5"</b>	930 mm	<b>3'1"</b>	1170 mm	<b>3'10"</b>	948 mm	<b>3'1"</b>
Reach with arm horizontal and bucket level		2420 mm	<b>7'11"</b>	2275 mm	<b>7'6"</b>	2610 mm	<b>8'7"</b>	2784 mm	<b>9'2"</b>
Operating Height Fully raised		5330 mm	<b>17'6"</b>	5145 mm	<b>16'11"</b>	5415 mm	<b>17'9"</b>	5773 mm	<b>18'11"</b>
Overall Length Bucket on Ground		7455 mm	<b>24'6"</b>	7310 mm	<b>24'0"</b>	7645 mm	<b>25'1"</b>	7943 mm	<b>26'1"</b>
Turning radius*		6090 mm	<b>20'0"</b>	6030 mm	<b>19'9"</b>	6165 mm	<b>20'3"</b>	6305 mm	<b>20'8"</b>
Digging Depth	0°	85 mm	<b>3.3"</b>	85 mm	<b>3.3"</b>	85 mm	<b>3.3"</b>	131 mm	<b>5'2"</b>
	10°	296 mm	<b>11.6"</b>	275 mm	<b>11.0"</b>	322 mm	<b>1'1"</b>	316 mm	<b>1'1"</b>
Breakout Force		13180 kg	<b>29,057 lb</b>	15100 kg	<b>33,290 lb</b>	11280 kg	<b>24,868 lb</b>	13604 kg	<b>29,992 lb</b>
Operating Weight		13880 kg	<b>30,600 lb</b>	13970 kg	<b>30,799 lb</b>	14070 kg	<b>31,019 lb</b>	14214 kg	<b>31,337 lb</b>

\* Bucket at carry, outside corner of bucket. At the end of tooth or BOCE.

All dimensions, weights, and performance values based on SAE J732c and J742b standards. Static tipping load and operating weight shown include lubricant, coolant, full fuel tank, ROPS cab, additional counterweight and operator. Machine stability and operating weight affected by counterweight, tire size, and other attachments.

**Weight Changes**

	Change in Operating Weight		Change in Tipping Load				Width Over Tire		Ground Clearance		Change in Vertical Dimensions	
			Straight		Full Turn							
20.5/25-12PR (L3)	160 kg	<b>353 lb</b>	120 kg	<b>265 lb</b>	104 kg	<b>229 lb</b>	2585 mm	<b>8'6"</b>	425 mm	<b>1'5"</b>	0 mm	<b>0"</b>
Install ROPS canopy (instead of cab)	-150 kg	<b>-331 lb</b>	-107 kg	<b>-239 lb</b>	-93 kg	<b>-205 lb</b>	N/A	N/A	N/A	N/A	N/A	N/A
Remove additional counterweight	-520 kg	<b>-1146 lb</b>	-1070 kg	<b>-2359 lb</b>	-940 kg	<b>-2072 lb</b>	N/A	N/A	N/A	N/A	N/A	N/A



## STANDARD EQUIPMENT

- Alternator, 60A, 24 volt
- Automatic boom kickout
- Axles, semi floating with torque proportioning
- Back-up alarm
- Back-up light, rear
- Batteries, 150 Ah/2 x 12 V, 1000 CCA
- Bucket positioner, automatic
- Cab ROPS/FOPS Level 2 with adjustable wrist rest, cigarette lighter/ash tray, dome light, electrically heated rear window, floor mat, front (intermittent) and rear wiper/washer, rear view mirrors (2 outside, 2 inside), right hand and left hand door access with steps, sun visor
- Counterweight, standard
- Differentials, torque proportioning
- Equipment Management Monitoring System (EMMS)
- Gauges (speedometer, engine water temperature, fuel level, HST oil temperature)
- LCD displays (filter/oil replacement time, HST selection, odometer, service meter, trouble shooting)
- Lights (axle oil temperature, battery charge, brake oil pressure, central warning, directional indicator, engine oil pressure, engine pre-heater, HST oil filter clogging, high beam, maintenance, parking brake reminder, parking brake warning, steering oil pressure, transmission speed range, turn signals)
- Engine, Komatsu SAA6D102E-2
- Engine shut-off system, electric
- Fan, hydraulic driven, swing out
- Fenders, full front, partial rear
- Fuel water separator
- Horn, electric
- Lift cylinders and bucket cylinder
- Lifting eyes
- Lights
  - Stop and tail
  - Turn signal (2 front, 2 rear)
  - Working (2 front, 2 rear, 2 outside cab)
- Loader linkage with standard lift boom
- Maintenance monitor panel
- 2 lever loader control
- Parking brake, wet multi-disc, mechanical
- Radiator mask, hinged
- Seat belt, retractable, 76 mm **3"** wide
- Seat, cloth, suspension, reclining with armrests and headrest, and a document holder
- Service brakes, hydraulic, wet multi-disc, inboard
- Speedometer (mph)
- Starting aid, intake manifold preheater
- Starting motor, 5.5 kW/24 V
- Steering wheel, tiltable
- Tires 20.5/25-12PR (L2), tubeless and rims
- Transmission (Hydrostatic with speed range select), automatic
- Transmission control, electric, steering column
- 2-spool valve for boom and bucket controls with PPC
- Vandalism protection kit



## OPTIONAL EQUIPMENT

- Air conditioner with heater/defroster/pressurizer
- Air ride seat
- Auxiliary steering
- Bucket, excavating, 2.3 m<sup>3</sup> **3.0 yd<sup>3</sup>**
- Bucket, stockpile, 2.8 m<sup>3</sup> **3.7 yd<sup>3</sup>**
- Bucket, light material, 3.2 m<sup>3</sup> **4.2 yd<sup>3</sup>**
- Bucket teeth, bolt-on
- Counterweight, additional 520 kg **1,146 lb**
- Cutting edge, bolt-on, reversible
- Electronically Controlled Suspension System (ECSS)
- Fenders, rear full
- Heater and defroster
- High-lift boom arrangement
- Hydraulic adapter kit (3rd spool), includes valve, lever, and piping
- JRB hydraulic quick coupler
- JRB bucket, general purpose, for use with coupler, with BOCE 2.6 m<sup>3</sup> **3.5 yd<sup>3</sup>**
- JRB construction forks, for use with coupler, 1524 mm mm **60"**
- JRB construction forks, for use with coupler, 1372 mm mm **54"**
- JRB extendable boom, 3-section, for use with coupler
- Limited-slip differential, front and rear
- Mono-lever loader control with transmission F/R switch
- Radio, AM/FM stereo with cassette
- Rims only, less tires
  - Fits 20.5/25, and 550/65 tires
- ROPS/FOPS Level 2 canopy
- Tires (bias ply)
  - 20.5/25-12PR (L3)
  - 20.5/25-16PR (L3)
- Brand preference, Goodyear
- Tires (radial ply)
  - 20.5-R25 VUT (L2) Bridgestone
  - 20.5-R25 XTLA (L2) Michelin
  - 20.5-R25 XHA (L3) Michelin
  - 20.5-R25 VMT (L3) Bridgestone
  - 550/65 R25 XTLA (L2) Michelin
  - 550/65 R25 XLD (L3) Michelin
- Vinyl seat

AESS640-06

©2007 Komatsu America Corp. Printed in USA

K07(5M) C

07/07 (EV-1)

# KOMATSU®

