

BROOKS
EQUIPMENT

☎ **1300 BROOKS** (1300 276 657)
@ sales@brooksequipment.com.au
🌐 www.brooksequipment.com.au



ISUZU
D-MAX

GO YOUR OWN WAY

THE FUTURE OF TOUGH



4x4 D-MAX X-TERRAIN in Volcanic Amber metallic



TESTED
2020 ★★★★★



Powered by its legendary turbo-diesel engine, the Isuzu D-MAX takes you to the next level of performance and reliability.

Welcome to the next generation of tough. From cutting-edge technology to the power you need, the D-MAX is more capable than ever before. Designed to handle the harshest of Australian conditions, it has everything you require to own your next adventure in style, comfort and maximum safety. Whether on or off-road, at work or at play, the D-MAX defines durability – today, and every day after.

Everything Isuzu has learned over a century of specialist engineering has led to this. The rugged, reliable, and refined Isuzu D-MAX. GO YOUR OWN WAY.

THE RUGGEDLY REFINED



4x4 D-MAX X-TERRAIN in Volcanic Amber metallic & Mercury Silver metallic



Muscular and modern, the Isuzu D-MAX commands attention at every turn.

The Isuzu D-MAX combines signature toughness with sleek urban charisma. Whether you're on a worksite, navigating the city or ruling off-road, it's bigger, bolder and even more decisive.

The D-MAX lights the way with LED Daytime Running Lights (DRLs) and ultra-bright Bi-LED headlights standard on the LS models and the top of the range X-TERRAIN. Taking style to another level, the X-TERRAIN features dark grey highlights and exclusive features such as an aero sports bar, fender flares and a lockable roller tonneau. And to make the ultimate statement, the X-TERRAIN is offered in Volcanic Amber – an exclusive metallic paint finish that's as confident as it is eye-catching. With its dominant stance and imposing presence, this is the supreme evolution of Isuzu's celebrated truck spirit.

- A BI-LED HEADLIGHTS:** Bi-LEDs illuminate further and wider. Standard on LS and X-TERRAIN models.
- B FRONT GRILLE:** With an unmistakably Isuzu attitude, the D-MAX grille is both rugged and stylish. The dark grey grille shown is standard on X-TERRAIN only.
- C LED TAIL LIGHTS:** Ultra-bright LED tail lights are standard on the LS-U range and X-TERRAIN.
- D ALLOY WHEELS:** Standard on X-TERRAIN models, dark grey 18" alloys feature a distinctive, darkened finish.

A detailed view of the interior of a 4x4 D-MAX X-TERRAIN truck. The image shows the front passenger seat and the driver's seat, both upholstered in black leather with red stitching accents. The driver's seat has a small 'SEATS' logo on the side. The dashboard, steering wheel, and center console are also visible, all in a dark, modern design. The background shows a cityscape through the windshield.

THE ULTIMATE IN COMFORT

4x4 D-MAX X-TERRAIN interior with leather accented seats¹

¹Seats have leather touches or accents, but are not wholly leather.



Effortless space. Intuitive design. Complete comfort.

Your Isuzu D-MAX is more than just a ute to get from A to B. It's your mobile office, your place to relax, and your passport to adventure. Whatever your purpose, the D-MAX's interior has been carefully crafted to suit your needs.

The first thing you'll notice is the D-MAX's stylish, richly appointed and technologically advanced cabin. It's never been simpler to find the perfect driver's position, with a redesigned, ergonomically optimised driver's seat, and tilt and telescopic adjustment of the steering wheel. With electric power steering, every corner of every drive will feel better than ever before. An extra layer of luxury is added for LS-U+ and X-TERRAIN models with leather accented seats*, an eight-way adjustable electric driver's seat with built-in powered lumbar support and variable heated front seats as standard, with the top of the range X-TERRAIN gaining striking red highlights throughout its interior.

Your passengers win too. All occupants enjoy softer cushioning with firmer lateral support, ample space and abundant storage. Reduced vibration and cabin noise make each journey a pleasure. The LS-U range and X-TERRAIN feature dual zone climate control, while a fine-particle pollen filter and rear-seat air vents feature on all crew cab models.

A ELECTRIC ADJUSTABLE DRIVER'S SEAT: Standard on LS-U+ and X-TERRAIN, an eight-way electrically adjustable driver's seat also offers customisable powered lumbar support. Powered lumbar support is also standard on the LS-U.

B REAR SEATS: 30/70 split fold seats standard on all crew cabs.

C DUAL ZONE AIR CONDITIONING: Standard on the LS-U range and X-TERRAIN models, both driver and passenger can select their own temperature preference.

D TILT & TELESCOPIC STEERING WHEEL: All models feature a height and reach-adjustable steering wheel for improved comfort and control.

*Seats have leather touches or accents, but are not wholly leather.



THE COMMAND CENTRE

4x4 D-MAX LS-U+ interior with leather accented seats*

*Seats have leather touches or accents, but are not wholly leather.



The Isuzu D-MAX features an array of advanced technology – all tailored to make your life easier.

The Isuzu D-MAX delivers all the technological convenience and functionality you've come to expect – and more.

Every D-MAX features a large, high-definition, customisable central touchscreen, with DAB+ digital radio, Android Auto™ and wireless Apple CarPlay®, as well as voice recognition. A large 4.2" digital display lets the driver access a variety of information in the instrument cluster via the steering wheel, including a digital speed reading. The LS-U range and X-TERRAIN models feature built-in satellite navigation as standard, while up to eight surround-sound in-cabin speakers put you in the front row of the concert on every journey.

An array of technology brings you closer to your car. Remote keyless entry features in every model, with the LS-U range and X-TERRAIN including smart keyless entry and push button start. The top of the range X-TERRAIN includes remote engine start to pre-cool your ute in summer or warm it in colder months. All D-MAXs offer automatic wipers, automatic headlights and all automatic models feature adaptive cruise control as standard, while the LS-U range and X-TERRAIN receive an auto-dimming rear view mirror, both LS-U+ and X-TERRAIN also feature heated side mirrors to help you keep a clear view at all times.



- A REMOTE ENGINE START:** The engine can be activated prior to entry with the push of a button. On X-TERRAIN only.
- B SMART TOUCH SCREEN DISPLAYS:** Apple CarPlay®/Android Auto™ and voice recognition is standard across the D-MAX range.
- C SMART MID:** Digital smart Multi-Information Display (MID) is standard across the range providing information on a variety of vehicle features.
- D REVERSING CAMERA:** Every D-MAX comes with a reversing camera and Rear CrossTraffic Alert (RCTA) as standard.

Apple CarPlay is a trademark of Apple Inc. Android Auto is a trademark of Google LLC. Not all devices will be compatible & functionality will vary depending on the device. Mobile Data & SMS rates may apply & are the responsibility of the user. Please check your local road rules before using these functions.

THE SMARTEST SAFEST CHOICE



TESTED
2020 ★ ★ ★ ★ ★



Cutting-edge and personalised driver assistance systems designed to protect and enhance your driving experience.

Every D-MAX model has achieved a maximum 5-star ANCAP safety rating thanks to Isuzu's Intelligent Driver Assistance System (IDAS[®]), which covers an extensive list of both active and passive safety features and is standard across the D-MAX range. Using state-of-the-art sensors and a stereo camera system, the D-MAX constantly monitors your surrounding environment for danger. Should it detect a collision is imminent, the system will work to help the driver to defuse dangerous situations via alert systems and automated functions. Each D-MAX model includes eight airbags as standard, and a stronger, more robust body and chassis as well as a reinforced cabin safety cell for ultimate protection in the case of an accident. You're in the safest of hands, wherever the journey takes you – even when you leave the road behind.

4x4 D-MAX X-TERRAIN in Cobalt Blue mica

*IDAS features are designed to assist the driver, but should not be relied upon nor used as a substitute for safe driving practices. Feature operation may vary in different driving conditions. For full explanation of limitations, see Owner's & Driver's Manual.



AUTONOMOUS EMERGENCY BRAKING (AEB): If your D-MAX detects a potential collision, emergency braking is applied automatically.



FORWARD COLLISION WARNING (FCW): An audible warning sounds and red warning lights flash on the dashboard when an obstacle is detected in your path.



ADAPTIVE CRUISE CONTROL: Automatically adjusts your speed based on vehicles around you, including Stop and Go functionality when cruise control is activated. (Automatic Transmission only).



BLIND SPOT MONITOR (BSM): Provides a visual warning in your side mirrors when an obstacle is approaching in your blind spot.



LANE KEEPING: Lane Keep Assist (LKA), Emergency Lane Keeping (ELK) and Lane Departure Prevention (LDP) work to help prevent collisions with other drivers should your D-MAX begin to drift across its lane. These features can also be disabled via the Lane Support System (LSS) switch.



TRAFFIC SIGN RECOGNITION: Your D-MAX recognises traffic signs, displaying information such as speed limits in the MID for easy reference.



FRONT & REAR PARKING SENSORS: Provides instantaneous feedback regarding nearby obstacles at low speed on X-TERRAIN models only. (LS-M and LS-U range ute models have rear sensors only as standard).



REVERSING CAMERA WITH REAR CROSS TRAFFIC ALERT (RCTA): Monitors your surrounding area while reversing into traffic, providing visual and audible warnings should an object approach from the left or right.

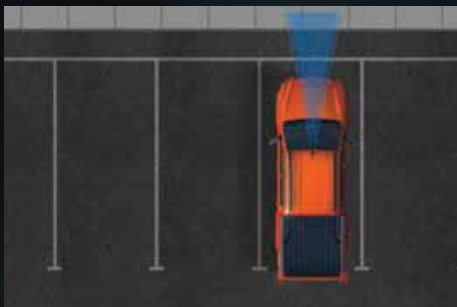

MISACCELERATION MITIGATION: In slow moving areas such as car parks, the stereo cameras determine whether the accelerator has been applied accidentally. Should a potential collision be detected, the accelerator is suppressed. (Automatic Transmission only).



AUTOMATIC HEADLIGHTS & HIGH BEAMS: Headlights automatically turn on when it is dark, such as at dusk or in underground car parks. During travel, the D-MAX dims the high beams automatically to avoid dazzling other drivers.



AUTOMATIC WINDSHIELD WIPERS: Every D-MAX has built-in rain-sensing wipers, ensuring you never lose sight of the road or trail ahead.



EIGHT AIRBAGS: For ultimate protection, every D-MAX comes with eight airbags including a centre airbag to protect front seat occupants in side-on collisions.

THE MUSCLE UNDER THE HOOD



4x4 D-MAX LS-U Crew Cab Ute in Mercury Silver metallic



A



B

Go your own way with 140kW of power and 450Nm of torque in the 3-litre turbo-diesel engine D-MAX.

The advanced 3-litre turbo-diesel common rail engine produces an avalanche of torque on demand. All 450Nm is available from just 1600rpm, providing maximum take-off and acceleration, while a broad, flat torque band aids driveability. With precise fuel injection control and low engine noise, improved aerodynamics and all the power you need, the D-MAX is more capable than ever before. Both the 3-litre and 1.9-litre turbo-diesel engines are Euro 5 compliant, helping every D-MAX deliver efficient fuel economy across the range.

Mated to a choice of manual or automatic 6-speed transmissions across both the 3-litre and 1.9-litre engines – the D-MAX demonstrates sophistication across its drivetrain. 6-speed manual transmissions in 3-litre engines benefit from a dual mass flywheel, which absorbs vibrations and torque pulses from the engine for smoother and more efficient drivability and transmission longevity. The 'Rev-Tronic' automatic transmission with sequential sports mode, automatically selecting the most appropriate shift and lock-up points according to driving style, vehicle load and road speed. Meanwhile, the short-throw gear lever in the manual D-MAX now boasts a superior pivot point – allowing for sportier, more palpable driving engagement.

Whether it's powering through the work week, crushing the weekend or going where the others won't, the Isuzu D-MAX is the complete performer.

C

3-Litre Engine Performance Curve

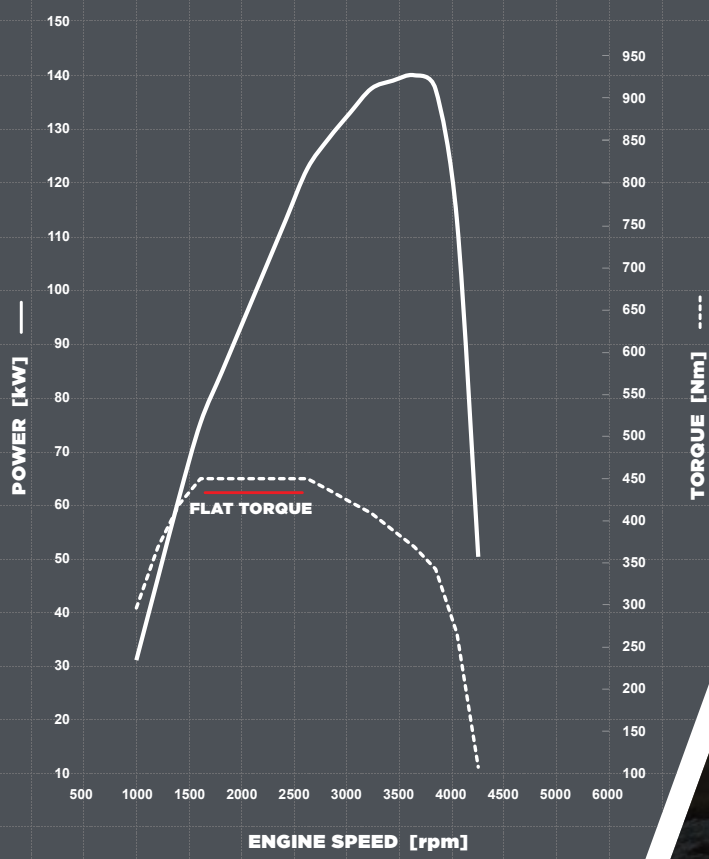

- A ISUZU 3-LITRE ENGINE: The advanced 4JJ3-TCX with plenty of real world power (140kW) and torque (450Nm).
- B 6-SPEED TRANSMISSION: The D-MAX features 6-speed automatic and manual transmission options across the range.
- C 3-LITRE ENGINE PERFORMANCE CURVE: A flat torque curve delivers 450Nm of torque from 1600rpm to 2600rpm.

THE POWER TO MOVE



4x4 D-MAX X-TERRAIN in Magnetic Red mica

With TSC

Without TSC



B



C



D

Strong, stable and always willing, the Isuzu D-MAX meets every challenge with up to 3.5-tonne towing*.

Your search for the perfect travelling companion is over. Isuzu's legendary turbo-diesel engine delivers high torque across the range, making light work of a caravan, boat, or trailer. When fitted with a genuine Isuzu UTE tow bar kit or tow tongue kit, every 3-litre engine D-MAX is able to tow up to 3.5 tonnes, while electric power steering ensures easy touring, no matter how long the journey – or how rough the conditions. Included across the range, Trailer Sway Control (TSC) can assist in bringing the towed vehicle back under control in high winds or uneven surfaces. Should it detect sway, TSC will attempt to assist by automatically applying the brakes on individual vehicle wheels, helping to stop your trailer from stepping out of line - and keeping you on the road. Serene and worry free.

Wider and stronger than ever, the D-MAX underwent the equivalent of over four million kilometres of testing during research and development – both on and off-road – and it shows. It emerged as the toughest ute in Isuzu's history, with an incredibly durable chassis and suspension tuned for Australian conditions. And you can further adapt your D-MAX, with an electronic brake controller kit and weight distribution hitch for ultimate control over your load.

- A TRAILER SWAY CONTROL (TSC):** Will apply brakes to individual vehicle wheels to help bring the trailer safely back under control.
- B OPTIONAL GENUINE WEIGHT DISTRIBUTION HITCH:** Ease the burden on the rear of your D-MAX by spreading the load evenly across the chassis with a genuine weight distribution hitch accessory.
- C TOW BAR RECEIVER:** Built-in to the LS-U range and X-TERRAIN models, you will be able to tow up to 3.5 tonnes when paired with a genuine tow tongue kit and optional 7-pin or 12-pin wiring harness.
- D OPTIONAL ELECTRONIC BRAKE CONTROLLER:** Maintain precise control of your heavy caravan or trailer's brakes from the comfort of the driver's seat.

*3.5-tonne braked towing capacity on all 3-litre engine D-MAX models, 3.0-tonne braked towing capacity on 1.9-litre engine automatic transmission models & 2.8-tonne braked towing capacity on 1.9-litre engine manual transmission models when fitted with an optional genuine Isuzu D-MAX tow bar kit or tow tongue kit.

THE ROAD LESS TRAVELLED



4x4 D-MAX X-TERRAIN in Volcanic Amber metallic



Designed from the ground up to handle Australia's toughest terrain, the Isuzu D-MAX comes alive off-road.

Wherever you're planning to go, your D-MAX is up for the task. With extensive steel underbody protection, a wading depth[†] of 800mm, and with a rear axle differential lock as standard on all 4x4 models, the D-MAX is your most reliable way to escape the everyday.

Engineered for Australian conditions, every 4x4 D-MAX features 'Terrain Command' as standard, allowing you to switch between 2WD-high and 4WD-high modes at speeds of up to 100km/h in less than a second. When the going gets tough, selecting 4WD-low will provide increased traction and complete control. Hill Start Assist (HSA) automatically prevents roll-back when starting on steep gradients (above 5.7 degrees), while Hill Descent Control (HDC) gives you maximum traction on rough downhill terrain. Add a turning circle of just 12.5 metres – meaning maximum manoeuvrability in tight spaces – and the D-MAX is supremely confident. Whatever the conditions. Wherever the location.

- A STEEL UNDERBODY PROTECTION:** Steel underbody guards on sump and transfer case on 4x4 models.
- B 800MM WADING DEPTH:** Water crossings are simple with a wading depth[†] of 800mm on all D-MAX models.
- C REAR DIFFERENTIAL LOCK:** Standard on all 4x4 models, the rear differential lock can be engaged with the push of a button when in 4WD-low.
- D TERRAIN COMMAND DIAL:** Switch quickly and easily between 2WD-high, 4WD-high and 4WD-low driving modes.

[†]Up to 800mm of wading depth on all D-MAX models when travelling at a consistent speed of 7km/h. Water ingress may occur if speed is not maintained or if the vehicle is static in water above 350mm.

THE TOUGH ISUZU DNA

ISUZU

Isuzu 4JJ3-TCX 3.0 litre turbo diesel engine

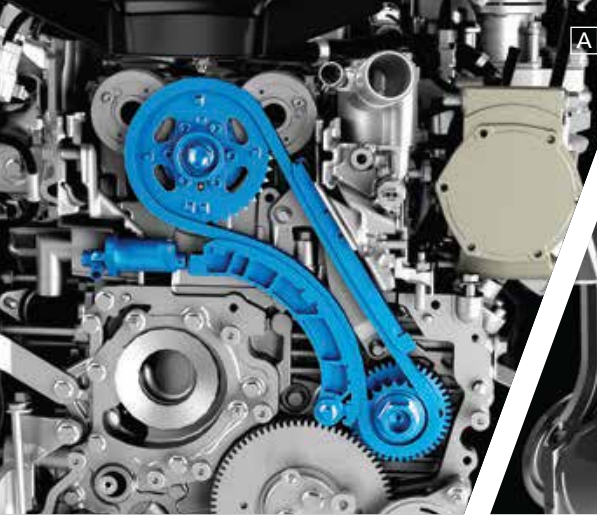
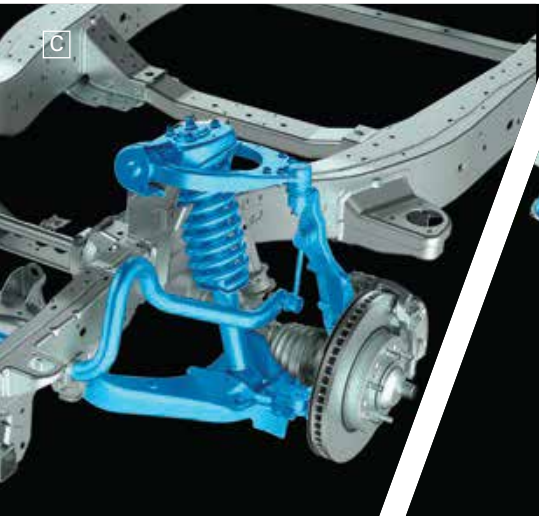
**A****B****C****D****E**

After a century of building the world's most reliable workhorses, the D-MAX is Isuzu's toughest ute – ever.

Having built more than 26 million engines internationally, Isuzu is the world leader in diesel engineering. Made to go the distance, the D-MAX has a legendary reputation for reliability. Over generations of commercial vehicle manufacturing, Isuzu has proven itself across Australia – and around the world.

The D-MAX's chassis is constructed with high tensile steel with extra cross members for added durability. Warm Stress Shot Peening (WSSP) long-span rear suspension is both stronger and more flexible, while independent double-wishbone front suspension with higher upper control arms improve handling for a more comfortable ride. The improved lightweight body provides improved overall stability, greater occupant protection, as well as reduced noise and vibration throughout the cabin.

- A STEEL TIMING CHAIN:** The steel timing chain found in the Isuzu engine is sturdier and lasts longer than a standard poly belt.
- B PISTONS:** Piston crowns and pins are coated with a special diamond-like carbon that improves durability and heat resistance, helping the engine work smoothly at maximum power.
- C FRONT SUSPENSION:** Higher mounted control arms minimise body roll when cornering and improve tyre grounding.
- D REAR LEAF SUSPENSION:** A lighter, but stronger leaf designed for Australian conditions creates a smoother ride.
- E DOUBLE SCISSOR GEARS:** A double scissor idler gear design results in reduced engine and gear noise for quieter and smoother operation.

Engine component imagery is representative of the 3-litre turbo-diesel engine & is for illustrative purposes only. Actual appearance may differ.

THE PERFECT FLEET



4x4 D-MAX LS-M Crew Cab Ute in Mercury Silver metallic
& 4x2 D-MAX SX Space Cab Chassis in Obsidian Grey mica
with optional Heavy Duty Alloy Tray



A



With 24 variants available, there's always an Isuzu D-MAX to suit your needs.

Precision engineered for durability and economy – and with a time-proven reputation for reliability – the D-MAX is the ultimate workhorse. The whole range is powered by Isuzu's robust 3-litre turbo-diesel engine, while the 4x2 SX Single Cab Chassis range gains exclusive access to a 1.9-litre engine option which provides lower emissions and better fuel efficiency. Whether your people need to go the distance on highways, into the outback or simply from site to site, the D-MAX range has been engineered for efficiency across your fleet, with fewer trips to the fuel pump and more time on the road.

The LS-U range and X-TERRAIN feature 18-inch highway-terrain tyres as standard, while all SX and LS-M models come with tough 17-inch all-terrain tyres as standard. They make light work of even the roughest ground while offering a smooth ride on tarmac – and low road noise. With Android Auto™ and wireless Apple CarPlay® across the range, your fleet can stay connected to the rest of the world.

With a maximum 5-star ANCAP safety rating and the Isuzu Intelligent Driver Assistance System (IDAS#) incorporated into every D-MAX, your workforce has never been better protected. Every IDAS safety feature is designed to improve driving practices and maintain driver alertness, as well as protecting pedestrians and other road users. Keeping your employees – and your investments – as safe as possible.

Isuzu UTE's Dealer network of over 150 Dealer locations spans every Australian state and territory, including regional and remote locations, ensuring that support is always close at hand. Our dedicated team of fleet managers are always available to ensure that your fleet requirements are met. Whether you're your own boss or heading up an international corporation, a D-MAX fleet is equipped to suit every aspect of your business.



B



C

- A 1.9-LITRE TURBO-DIESEL ENGINE:** The RZ4E-TC 1.9-litre turbo-diesel engine is an exclusive option for the 4x2 SX Single Cab Chassis range and provides excellent fuel efficiency from 7.0L per 100km⁴.
- C SPACE CAB DESIGN:** Ample storage behind the front seats can be easily accessed via rear 'wing' doors.
- C SX GRADE INTERIOR CABIN:** SX interior with 7" touchscreen featuring Android Auto™ and wireless Apple CarPlay®.

Apple CarPlay is a trademark of Apple Inc. Android Auto is a trademark of Google LLC. Not all devices will be compatible & functionality will vary depending on the device. Mobile Data & SMS rates may apply & are the responsibility of the user. Please check your local road rules before using these functions. ⁴Fuel consumption & emissions figures based on ADR 81/02 & are to be used for vehicle comparison purposes only. Actual fuel consumption & emissions will vary depending on many factors including, but not limited to, traffic conditions, individual driving style & vehicle condition. [#]IDAS features are designed to assist the driver, but should not be relied upon nor used as a substitute for safe driving practices. Feature operation may vary in different driving conditions. For full explanation of limitations, see Owner's & Driver's Manual.

THE ADVENTURE STARTS HERE



4x4 D-MAX LS-M Crew Cab Ute in Mercury Silver metallic &
4x4 D-MAX LS-U Crew Cab Ute in Cobalt Blue mica fitted with
optional Isuzu UTE Genuine Accessories

Go your own way for longer with Isuzu UTE Service Plus, I-Venture Club, Isuzu UTE Genuine Accessories and Isuzu UTE Approved Accessories.

SERVICE PLUS

All D-MAX owners enjoy ultimate peace of mind with Isuzu UTE's comprehensive Service Plus program. As part of this program your D-MAX is covered for six years/150,000km of warranty. While Isuzu's Roadside Assistance Program guarantees support for a minimum of 13 months – and up to seven years in total. Capped price servicing applies for the seven years/105,000km. And with a sprawling network covering all states and territories, your local Isuzu UTE service centre will keep your D-MAX performing at its best – wherever you find yourself.

I-VENTURE CLUB

You won't want to miss the opportunity to properly test your D-MAX's potential – and to visit Australia's most inspiring 4WD locations! The I-Venture Club is an opportunity to build your 4x4 skills and become the off-road champion you've always wanted to be. As an Isuzu UTE owner, you can sign up for exclusive trips that tackle some of the country's most challenging off-road destinations. Learn from our qualified 4x4 instructors, meet like-minded budding adventurers, and come away with the skills to handle the toughest terrain a D-MAX can find. Head to www.iventureclub.com.au for a taste of what's to come.

GENUINE ACCESSORIES

Isuzu UTE Genuine Accessories¹ are the key to taking on more challenging terrain in true 'Go your own way' style. Isuzu UTE's extensive range of accessories allows you to enhance and personalise your ride with precision engineered parts of the highest quality, with correct fit guaranteed every time. Each genuine accessory comes with a comprehensive warranty, providing ultimate peace of mind, and the chance to pack more, do more, or just add a little more style to your D-MAX. See the full range of accessories in the D-MAX Accessories brochure or at isuzuute.com.au.

APPROVED ACCESSORIES

Isuzu UTE Approved Accessories² are third-party branded accessories that have been thoroughly tested and vetted to ensure they meet Isuzu's highest standards. Constructed for local conditions by a variety of Australian manufacturers you know and trust, they provide another way to enhance and personalise your D-MAX with the confidence of Isuzu UTE Australia's seal of approval. Whether used in combination with Genuine Accessories or without, Isuzu UTE Approved Accessories can be trusted to maintain the integrity of your D-MAX – while also offering a distinctly individual touch. See the full range of accessories in the D-MAX Accessories brochure or at isuzuute.com.au.

SERVICE PLUS



I-VENTURE CLUB

**ISUZU UTE
GENUINE ACCESSORIES**

**ISUZU UTE
APPROVED ACCESSORIES**

¹6 years/150,000km (whichever occurs first), for Isuzu UTE Vehicles with a Warranty Start Date on or after 1/1/19. Excludes accessories & trays. ²The Roadside Assistance Program ("RSA Program") provides Coverage to RSA Eligible Vehicles with a Warranty Start Date on or after 1/9/20 for a maximum of 7 years (unlimited kilometres). Initial 13 months Coverage provided from the Warranty Start Date. The Coverage will be reset for another 13 months from each date that a Participating Isuzu UTE Dealer conducts a Scheduled Service on the vehicle. For full terms & conditions visit isuzuute.com.au/roadside-assistance-disclaimer. ³The Capped Price Servicing Program ("CPS Program") applies to CPS Eligible Vehicles at Participating Isuzu UTE Dealers only. For 19MY & later vehicle models, the Capped Price Servicing covers the first 7 Scheduled Services for up to 7 years/105,000km (whichever occurs first). CPS Program is subject to change. For full terms & conditions, current pricing & model eligibility visit isuzuute.com.au/service-plus-disclaimer. ⁴Warranty for Isuzu UTE Genuine Accessories fitted by an authorised Isuzu UTE Dealer at the point of sale of a new Isuzu UTE vehicle are covered for three (3) years or 100,000 kilometres, whichever occurs first; Isuzu UTE Genuine Accessories fitted by an authorised Isuzu UTE Dealer after the delivery of a new Isuzu UTE vehicle are covered for one (1) year or 40,000 kilometres from the date of accessory purchase, whichever occurs first; Isuzu UTE Genuine Accessories not fitted by an authorised Isuzu UTE Dealer are warranted from the date of purchase for one (1) year or 20,000 kilometres, whichever occurs first. ⁵Isuzu UTE Approved Accessories are not manufactured or warranted by Isuzu UTE Australia Pty Ltd. The warranty is provided by the manufacturer of the accessory. For more information refer to the Isuzu D-MAX Accessories brochure.

THE CHOICE IS YOURS



Powered by the tried and tested Isuzu turbo-diesel engine and backed by advanced IDAS safety features, the next generation Isuzu D-MAX is ready to help you go your own way.

D-MAX SX (22MY)



4x4 D-MAX SX Crew Cab Ute Manual interior shown. Seat shape will vary depending on cabin type.

Cabin Types



Single Cab Chassis
(4x2 & 4x4)



Space Cab Chassis
(4x2 & 4x4)



Crew Cab Chassis
(4x2 & 4x4)



Crew Cab Ute
(4x2 & 4x4)

Engine Types



Model shown is 4x4 D-MAX SX Single Cab Chassis in Mineral White with an optional Heavy Duty Alloy Tray

SX key features

1.9-litre & 3-litre engine variants available

Tilt & Telescopic Adjustable Steering Wheel

Electric Power Steering

Easy-Clean Vinyl Flooring

7" Touchscreen Audio with Android Auto™ & wireless Apple CarPlay® Compatibility

Reversing Camera

Black Handles & Mirrors

17" Steel Wheels & 255 65 R17 All-Terrain Tyres

Matte Grey Grille

Halogen Headlights

Available colours



Basalt Black mica



Cobalt Blue mica



Mercury Silver metallic



Obsidian Grey mica



Mineral White

D-MAX LS-M (22MY)



Cabin Type



Crew Cab Ute
(4x4 only)



Crew Cab Chassis
(4x4 only)

Model shown is 4x4 D-MAX LS-M Crew Cab Ute in Cobalt Blue mica

LS-M key features

Tilt & Telescopic Adjustable Steering Wheel

Electric Power Steering

Easy-Clean Vinyl Flooring

High Grade Cloth Seats

7" Touchscreen Audio with Android Auto™ & wireless Apple CarPlay® Compatibility

Reversing Camera with Rear Park Assist Sensors (Cab Chassis model has Reversing Camera only)

Body Colour Handles & Mirrors

LED Fog Lights

17" Alloy Wheels & 255 65 R17 All-Terrain Tyres

Matte Grey Grille

Bi-LED Headlights with Auto Levelling

Available colours



Basalt Black mica



Cobalt Blue mica



Mercury Silver metallic



Obsidian Grey mica



Mineral White



D-MAX LS-U (22MY)



Cabin Types



Space Cab Ute
(4x4 only)



Crew Cab Ute
(4x2 & 4x4)



Crew Cab Chassis
(4x4 only)

Model shown is 4x4 D-MAX LS-U Space Cab Ute in Magnetic Red mica

LS-U key features

Tilt & Telescopic Adjustable Steering Wheel

Leather Steering Wheel

Smart Keyless Entry & Push Button Start

Auto-dimming Rear View Mirror

Electric Power Steering

Carpet Flooring

High Grade Cloth Seats

9" Touchscreen Audio with Android Auto™ & wireless Apple CarPlay® Compatibility

Reversing Camera with Rear Park Assist Sensors (Cab Chassis model has Reversing Camera only)

18" Two-Tone Machined Alloy Wheels & 265 60 R18 Highway-Terrain Tyres

Chrome Grille, Handles & Mirrors

Bi-LED Headlights with Auto Levelling

Power Lumbar Support Driver's Seat

Dual Zone Climate Control Air Conditioning (with rear seat vents in Crew Cab)

Silver Aluminium Side Steps

Under Rail Tub Liner

Tow Bar Receiver

Available colours



Basalt Black mica



Cobalt Blue mica



Mercury Silver metallic



Obsidian Grey mica



Mineral White



Marble White pearl



Magnetic Red mica



D-MAX LS-U+ (22MY)



Cabin Types



Crew Cab Ute
(4x4 only)

Model shown is 4x4 D-MAX LS-U+ Crew Cab Ute in Mercury Silver metallic

LS-U+ key features

Tilt & Telescopic Adjustable Steering Wheel

Leather Steering Wheel

Smart Keyless Entry & Push Button Start

Auto-dimming Rear View Mirror &
Heated Door Mirrors

Electric Power Steering

Carpet Flooring

Leather Accented Seats* with Heated Front Seats

9" Touchscreen Audio with Android Auto™ &
wireless Apple CarPlay® Compatibility

Reversing Camera with Rear Park Assist Sensors

18" Two-Tone Machined Alloy Wheels & 265 60
R18 Highway-Terrain Tyres

Chrome Grille, Handles & Mirrors

Bi-LED Headlights with Auto Levelling

Electric Eight-Way Adjustable Driver's Seat with
Power Lumbar Support

Dual Zone Climate Control Air Conditioning
(with rear seat vents)

Silver Aluminium Side Steps

Under Rail Tub Liner

Tow Bar Receiver

Available colours



Basalt Black mica



Cobalt Blue mica



Mercury Silver metallic



Obsidian Grey mica



Mineral White



Marble White pearl



Magnetic Red mica



D-MAX X-TERRAIN (22MY)



Cabin Type



Crew Cab Ute
(4x4 only)

Model shown is 4x4 D-MAX X-TERRAIN in Volcanic Amber metallic

X-TERRAIN key features

Smart Keyless Entry & Push Button Start
Remote Engine Start & Walk Away Door Lock
Tilt & Telescopic Adjustable Steering Wheel
Electric Power Steering
Carpet Flooring with Darkened Interior Finish
Auto-dimming Rear View Mirror & Heated Door Mirrors
Leather Accented Seats* with Red Stitching and Heated Front Seats
9" Touchscreen Audio with Android Auto™ & wireless Apple CarPlay® Compatibility
Bi-LED Headlights with Auto Levelling

Front & Rear Park Assist Sensors with Reversing Camera
18" Dark Grey Alloy Wheels & 265 60 R18 Highway-Terrain Tyres
Electric Eight-Way Adjustable Driver's Seat with Power Lumbar Support
Dual Zone Climate Control Air Conditioning (with rear seat vents)
Dark Grey Grille, Side Steps, Fender Flares & Aero Sports Bar
Black Roller Tonneau Cover
Under Rail Tub Liner
Tow Bar Receiver



Available colours



All features mentioned are a guide for quick comparison. Refer to the D-MAX specification list for further details on available features. Apple CarPlay is a trademark of Apple Inc. Android Auto is a trademark of Google LLC. Not all devices will be compatible & functionality will vary depending on the device. Mobile Data & SMS rates may apply & are the responsibility of the user. Please check your local road rules before using these functions. *Seats have leather touches or accents but are not wholly leather.

22MY ISUZU D-MAX SPECIFICATIONS

Engine	3.0L	1.9L
Series	Isuzu 4JJ3-TCX	RZ4E-TC
Description	3-litre turbo-diesel, in-line 4-cylinder, DOHC, 16-valve with Diesel Particulate Diffuser (DPD)	1.9-litre turbo-diesel, in-line 4-cylinder, DOHC, 16-valve with Diesel Particulate Diffuser (DPD)
Maximum torque	450Nm @ 1600→2600 rpm (automatic & manual)	350Nm @ 1800→2600 rpm (automatic and manual)
Maximum power	140kW @ 3600 rpm	110kW @ 3600 rpm
Bore x stroke	95.4mm x 104.9mm	80mm x 94.4mm
Displacement	2999cc	1898cc
Compression ratio	16.3 : 1	15.9: 1
Cylinder head	Isuzu-patent special aluminium alloy	Isuzu-patent special aluminium alloy
Valve gear	Chain-driven dual overhead camshafts, roller rockers, 4 valves/cylinder	Chain-driven dual overhead camshafts, roller rockers, 4 valves/cylinder
Induction	Electronic high pressure common rail direct fuel injection with VSS (Variable Swirl System) and intercooled electric control VGS (Variable Geometry System) turbocharger	Electronic high pressure common rail direct fuel injection with VSS (Variable Swirl System) and intercooled electric control VGS (Variable Geometry System) turbocharger
Cylinder block	Cast iron upper with induction-hardened cylinder bores, cast alloy lower	Cast iron upper with induction-hardened cylinder bores, cast alloy lower
Emission level	Euro 5	Euro 5
Alternator	90 amp with Intelligent Battery Sensor (IBS)	90 amp with Intelligent Battery Sensor (IBS)

Transmissions

Manual	3.0L Engine: Isuzu MVL6S 6-speed manual with high torque capacity and output reduction, 275mm diameter clutch plate and dual mass flywheel 1.9L Engine: Isuzu MVL6Y 6-speed manual with high torque capacity and output reduction, 275mm diameter clutch plate and single mass flywheel					
Automatic	Aisin AWR6B45 II 6-speed with sequential shift and brake shift lock electronically controlled, tri-mode with fuel-saving lock-up torque converter on gears 3, 4, 5 and 6 ► Uphill/Downhill Transmission Control: holds gear in varied-gradient ascents, selects gear on steep descents to hold speed with engine braking					
Ratios: 1	3.0L Turbo	6-speed Manual	6-speed Automatic	1.9L Turbo	6-speed Manual	6-speed Automatic
	1st	4.942	3.600	1st	4.942	3.600
	2nd	2.452	2.090	2nd	2.686	2.090
	3rd	1.428	1.488	3rd	1.527	1.488
	4th	1.000	1.000	4th	1.000	1.000
	5th	0.749	0.687	5th	0.749	0.687
	6th	0.634	0.580	6th	0.634	0.580
	Reverse	4.597	3.732	Reverse	4.597	3.732
Final drive	4x2	3.727	3.727	4x2	4.100	4.100
	4x4	3.727	3.727		-	-
	Snorkelled diff breathers to increase fording depth and reduce mud blockage					
Transfer gearing	4x4 low-range	2.482	2.482			
	4x4 high-range	1.000	1.000			
4x4 system	"Terrain Command" control with 'shift on the fly' 2-high↔4-high selection at up to 100km/h, 4-low with rear differential lock					
Drivetrain system	TCS (Traction Control System) on all model variants					

Steering

Electric power steering with speed-sensing steering feel (light at low speed, heavy at high speed); tilt and telescopic adjustable steering wheel
Engine-speed-sensitive variable capacity Electric power system; 3.84 turns lock-to-lock via tilt-adjustable steering wheel

Chassis

Separate, full-length heavy-duty chassis with 8 cross members on all models

Front suspension

Independent, high-ride, coil springs, gas shock absorbers, upper and lower wishbones, stabiliser bar

Rear suspension

LS-M and all Cab Chassis models: Heavy Duty alloy-steel overslung long-span semi-elliptic leaf springs; gas shock absorbers

4x2 and 4x4 models: Alloy-steel overslung long-span semi-elliptic leaf springs; gas shock absorbers

Axles

Front	Independent 4x4: fully floating with outer CV, inner double offset joints and equal length driveshafts. Rating: 1450kg
Rear	Rigid semi-floating banjo with hypoid final drive and dual tapered needle roller bearings. Rating: 1910kg

Brakes

Anti-lock Brake System (ABS) with Electronic Brakeforce Distribution (EBD), Electronic Stability Control (ESC), Emergency Brake Assist (EBA), Traction Control System (TCS), Rollover Mitigation, Hill Start Assist (HSA), Hill Descent Control (HDC) and Trailer Sway Control (TSC)

320mm dia. ventilated front discs with 2-piston calipers, 295mm rear drums

Power-assisted via 10" servo unit; central pull up park brake

Wheels and Tyres

SX	17" x 7" drilled silver-finish steel; 255 / 65 R17 All-Terrain
LS-M	17" x 7" alloy; 255 / 65 R17 All-Terrain
LS-U and LS-U+	18" x 7.5" alloy; 265 / 60 R18 Highway-Terrain
X-TERRAIN	18" x 7.5" dark grey alloy; 265 / 60 R18 Highway-Terrain
All Models	Full size steel spare wheel

Service Plus

Warranty	For the ultimate peace of mind, every Isuzu D-MAX comes standard with a comprehensive, bumper-to-bumper 6 years/150,000km warranty ¹ .
Roadside Assistance	Enjoy up to 7 years Roadside Assistance ² when you complete your scheduled services at a Participating Isuzu UTE Dealer.
Capped Price Servicing	As an owner you will get access to our Capped Price Servicing ³ Program. The CPS Program covers the first 7 Scheduled Services in line with the Scheduled Service Intervals.

¹6 years/150,000km (whichever occurs first), for Isuzu UTE Vehicles with a Warranty Start Date on or after 1/1/19. Excludes trays & accessories. ²The Roadside Assistance Program ("RSA Program") provides Coverage to RSA Eligible Vehicles with a Warranty Start Date on or after 1/9/20 for a maximum of 7 years (unlimited kilometres). Initial 13 months Coverage provided from the Warranty Start Date. The Coverage will be reset for another 13 months from each date that a Participating Isuzu UTE Dealer conducts a Scheduled Service on the vehicle. For full terms & conditions visit isuzuute.com.au/roadside-assistance-disclaimer. ³The Capped Price Servicing Program ("CPS Program") applies to CPS Eligible Vehicles at Participating Isuzu UTE Dealers only. For 19MY & later vehicle models, the Capped Price Servicing covers the first 7 Scheduled Services for up to 7 years/105,000km (whichever occurs first). CPS Program is subject to change. For full terms & conditions, current pricing & model eligibility visit isuzuute.com.au/service-plus-disclaimer.

Safety

IDAS	Every D-MAX comes with Isuzu's Intelligent Driver Assistance System (IDAS ⁴) built-in to protect and enhance the driving experience. IDAS includes smart technologies as well as other passive and active safety features.
------	--

⁴IDAS features are designed to assist the driver, but should not be relied upon nor used as a substitute for safe driving practices. Feature operation may vary in different driving conditions. For full explanation of limitations, see Owner's & Driver's Manual.

ANCAP RATING	The entire D-MAX range has achieved a maximum 5-star ANCAP safety rating in 2020.
--------------	---

SPECIFICATIONS

	4x2 High-Ride					4x4*										
	Single Cab Chassis SX	Space Cab Chassis SX	Crew Cab Chassis SX	Crew Cab Ute SX	Crew Cab Ute LS-U	Single Cab Chassis SX	Space Cab Chassis SX	Space Cab Ute LS-U	Crew Cab Chassis SX	Crew Cab Ute SX	Crew Cab Chassis LS-M	Crew Cab Ute LS-M	Crew Cab Chassis LS-U	Crew Cab Ute LS-U	Crew Cab Ute LS-U+	Crew Cab Ute X-TERRAIN
Engine																
1898cc DOHC 4cyl. with intercooled turbocharger (350Nm, 110kW)	●					●	●	●	●	●	●	●	●	●	●	●
2999cc DOHC 4cyl. with intercooled turbocharger (450Nm, 140kW)	●	●	●	●	●	●	●	●	●	●	●	●	●	●	●	●
Transmissions																
6-speed manual transmission	●					●	●		●			●		●		
6-speed "Rev-Tronic" automatic transmission with sequential sport mode	●	●	●	●	●	●	●	●	●	●	●	●	●	●	●	●
Safety and Security																
4-channel 4-sensor Anti-lock Brake System (ABS) with Electronic Brakeforce Distribution (EBD)	●	●	●	●	●	●	●	●	●	●	●	●	●	●	●	●
Electronic Stability Control (ESC)	●	●	●	●	●	●	●	●	●	●	●	●	●	●	●	●
Traction Control System (TCS)	●	●	●	●	●	●	●	●	●	●	●	●	●	●	●	●
Emergency Brake Assist (EBA)	●	●	●	●	●	●	●	●	●	●	●	●	●	●	●	●
Hill Start Assist (HSA)	●	●	●	●	●	●	●	●	●	●	●	●	●	●	●	●
Hill Descent Control (HDC)	●	●	●	●	●	●	●	●	●	●	●	●	●	●	●	●
Autonomous Emergency Braking (AEB)	●	●	●	●	●	●	●	●	●	●	●	●	●	●	●	●
Turn Assist with AEB	●	●	●	●	●	●	●	●	●	●	●	●	●	●	●	●
Post-Collision Braking	●	●	●	●	●	●	●	●	●	●	●	●	●	●	●	●
Forward Collision Warning (FCW)	●	●	●	●	●	●	●	●	●	●	●	●	●	●	●	●
Misacceleration Mitigation (*AT models only)	●*	●	●	●	●	●*	●*	●	●*	●	●	●	●	●	●	●
Adaptive Cruise Control (ACC) with Stop and Go functionality (*AT models only)	●*	●	●	●	●	●*	●*	●	●*	●	●	●*	●	●*	●	●
Traffic Sign Recognition (TSR)	●*	●	●	●	●	●*	●*	●	●*	●	●	●*	●	●*	●	●
Intelligent Speed Limiter	●	●	●	●	●	●	●	●	●	●	●	●	●	●	●	●
Manual Speed Limiter	●	●	●	●	●	●	●	●	●	●	●	●	●	●	●	●
Lane Departure Warning (LDW)	●	●	●	●	●	●	●	●	●	●	●	●	●	●	●	●
Lane Departure Prevention (LDP)	●	●	●	●	●	●	●	●	●	●	●	●	●	●	●	●
Lane Keep Assist (LKA) (*AT models only)	●*	●	●	●	●	●*	●*	●	●*	●	●*	●	●*	●	●*	●
Emergency Lane Keeping (ELK)	●*	●	●	●	●	●*	●*	●	●*	●	●*	●	●*	●	●*	●
Lane Support System (LSS) Switch (disables LDW, LDP, LKA, ELK)	●	●	●	●	●	●	●	●	●	●	●	●	●	●	●	●
Driver Attention Assist	●	●	●	●	●	●	●	●	●	●	●	●	●	●	●	●
Blind Spot Monitoring (BSM)	●	●	●	●	●	●	●	●	●	●	●	●	●	●	●	●
Rear Cross Traffic Alert (RCTA)	●	●	●	●	●	●	●	●	●	●	●	●	●	●	●	●
Reversing camera	●	●	●	●	●	●	●	●	●	●	●	●	●	●	●	●
Rear parking sensors					●							●		●		●
Front parking sensors					●							●		●		●
8 Airbags: dual front, curtain, side, driver's knee and far side airbags	●	●	●	●	●	●	●	●	●	●	●	●	●	●	●	●
Passenger side SRS airbag on/off switch	●	●	●	●	●	●	●	●	●	●	●	●	●	●	●	●
Height-adjustable upper mounts for front seat belts	●	●	●	●	●	●	●	●	●	●	●	●	●	●	●	●
Pre-tensioners with load limiters for front seat belts	●	●	●	●	●	●	●	●	●	●	●	●	●	●	●	●
Pre-tensioners with load limiters for outer rear seat belts			●	●	●			●	●	●	●	●	●	●	●	●
3-point retractable seat belts for all rear and centre seating positions			●	●	●			●	●	●	●	●	●	●	●	●
Intelligent seatbelt reminder (all seats)	●	●	●	●	●	●	●	●	●	●	●	●	●	●	●	●
2 childseat tethers and ISO FIX compatible anchor points			●	●	●			●	●	●	●	●	●	●	●	●
Height-adjustable head restraints for full-size seats		●	●	●	●		●	●	●	●	●	●	●	●	●	●
Integrated head restraint on front seats	●					●										
Child-proof rear door locks			●	●	●				●	●	●	●	●	●	●	●
Single 10 inch servo brake master cylinder	●	●	●	●	●	●	●	●	●	●	●	●	●	●	●	●
Side anti-intrusion bars inside all doors	●	●	●	●	●	●	●	●	●	●	●	●	●	●	●	●
Engine immobilizer	●	●	●	●	●	●	●	●	●	●	●	●	●	●	●	●
Rear window demister		●	●	●	●		●	●	●	●	●	●	●	●	●	●
High Density Polyethylene (HDPE) fuel tank	●	●	●	●	●	●	●	●	●	●	●	●	●	●	●	●
High mount brake light on cabin	●	●	●	●	●	●	●	●	●	●	●	●	●	●	●	●
Dual horn	●	●	●	●	●	●	●	●	●	●	●	●	●	●	●	●
Protection																
Under-front steel skid plate	●	●	●	●	●	●	●	●	●	●	●	●	●	●	●	●
Steel plate guards: sump, transfer case, fuel tank leading edge; reinforced resin under fuel tank	●	●	●	●	●	●	●	●	●	●	●	●	●	●	●	●
Suspension and Brakes																
Standard rear leaf suspension				●	●				●	●				●	●	●
Heavy duty rear leaf suspension	●	●	●			●	●		●	●	●	●		●	●	●
Front independent, coil spring suspension w/gas shock absorbers, upper and lower wishbones and stabiliser bar	●	●	●	●	●	●	●	●	●	●	●	●	●	●	●	●
Heavy-duty brakes: 320mm ventilated front discs w/twin-pot calipers, 295mm rear drums	●	●	●	●	●	●	●	●	●	●	●	●	●	●	●	●

*Limited stock available on these models. Please contact your local Isuzu UTE Dealer for more information.

SPECIFICATIONS

In-cabin Storage

	4x2 High-Ride					4x4*										
	Single Cab Chassis SX	Space Cab Chassis SX	Crew Cab Chassis SX	Crew Cab Ute SX	Crew Cab Ute LS-U	Single Cab Chassis SX	Space Cab Chassis SX	Space Cab Ute LS-U	Crew Cab Chassis SX	Crew Cab Ute SX	Crew Cab Chassis LS-M	Crew Cab Ute LS-M	Crew Cab Chassis LS-U	Crew Cab Ute LS-U	Crew Cab Ute LS-U+	Crew Cab Ute X-TERRAIN
Lower glovebox compartment only	●	●	●	●		●	●		●	●		●	●	●	●	●
Upper and lower glovebox compartments					●			●			●	●	●	●	●	●
Power outlet in lower instrument panel	●	●	●	●	●	●	●	●	●	●	●	●	●	●	●	●
Centre floor console	●	●	●	●	●	●	●	●	●	●	●	●	●	●	●	●
Dual-purpose driver and front passenger cup holder tray	●	●	●	●	●	●	●	●	●	●	●	●	●	●	●	●
Rear passenger door cup holders			●	●	●			●	●	●	●	●	●	●	●	●
Pockets on backs of front seats				●	●			●	●	●	●	●	●	●	●	●
Overhead console with twin map lights and flip-down sunglasses case	●	●	●	●	●	●	●	●	●	●	●	●	●	●	●	●
Front door storage compartment with bottle bulge	●	●	●	●	●	●	●	●	●	●	●	●	●	●	●	●
2 coat hooks			●	●	●			●	●	●	●	●	●	●	●	●
Flip up convenience hook behind passenger front seat				●	●			●	●	●	●	●	●	●	●	●
Tool storage behind rear seats		●	●	●	●			●	●	●	●	●	●	●	●	●
Tool storage behind front seats	●					●										

Rear Tub

Double-walled ute tub				●	●			●	●		●		●	●	●	●
4 cargo tie-down hooks inside ute tub				●	●			●	●		●		●	●	●	●
Under rail tub liner					●			●	●		●		●	●	●	●
2 cargo tie-down hooks inside ute tub					●			●	●		●		●	●	●	●

Exterior Style

Short front overhang for optimal manoeuvrability and approach angle	●	●	●	●	●	●	●	●	●	●	●	●	●	●	●	●
Halogen multi-reflector project lens headlights for extra low beam depth and reduced flare	●	●	●	●	●	●	●	●	●	●	●	●	●	●	●	●
Bi-LED headlights with auto-levelling function					●			●	●		●	●	●	●	●	●
Automatic headlights	●	●	●	●	●	●	●	●	●	●	●	●	●	●	●	●
Automatic high beam	●	●	●	●	●	●	●	●	●	●	●	●	●	●	●	●
Coming home light	●	●	●	●	●	●	●	●	●	●	●	●	●	●	●	●
Welcome light					●			●	●		●	●	●	●	●	●
LED Daytime Running Lights (DRLs)					●			●	●		●	●	●	●	●	●
LED fog lights					●			●	●		●	●	●	●	●	●
Matte grey radiator grille	●	●	●	●	●	●	●	●	●	●	●	●	●	●	●	●
Chrome radiator grille					●			●	●		●	●	●	●	●	●
Dark grey radiator grille																●
Colour-coded front bumper	●	●	●	●	●	●	●	●	●	●	●	●	●	●	●	●
Integrated Rear Step Bumper (Colour-coded)				●	●			●	●		●	●	●	●	●	●
Rear Bumper (Black)	●	●	●		●	●	●	●	●	●	●	●	●	●	●	●
Factory fitted tow bar receiver					●			●	●		●	●	●	●	●	●
Space cab rear "wing" doors		●						●	●		●	●	●	●	●	●
Aluminium side steps					●			●	●		●	●	●	●	●	●
Dark grey side steps																●
Black door and tailgate handles	●	●	●	●	●	●	●	●	●		●	●	●	●	●	●
Colour-coded door and tailgate handles										●	●					
Chrome door and tailgate handles								●	●		●	●	●	●	●	●
Dark grey door and tailgate handles																●
Lockable tailgate				●	●			●	●		●	●	●	●	●	●
Aero sports bar																●
Matte black roller tonneau																●
Front and rear underbody spoilers																●
Dark grey fender flares																●
Black roof rails																●
Black power door mirrors	●	●	●	●	●	●	●	●	●		●	●	●	●	●	●
Colour-coded power door mirrors with integrated turn indicators										●	●					●
Chrome fold-in power door mirrors with integrated turn indicators					●			●	●		●	●	●	●	●	●
Dark grey fold-in power door mirrors with integrated turn indicators																●
Heated door mirrors																●
Centre front roof-mounted bee-sting aerial	●	●	●	●	●	●	●	●	●	●	●	●	●	●	●	●
LED rear combination lamps					●			●	●		●	●	●	●	●	●

SPECIFICATIONS

Seating

	4x2 High-Ride					4x4*										
	Single Cab Chassis SX	Space Cab Chassis SX	Crew Cab Chassis SX	Crew Cab Ute SX	Crew Cab Ute LS-U	Single Cab Chassis SX	Space Cab Chassis SX	Space Cab Ute LS-U	Crew Cab Chassis SX	Crew Cab Ute SX	Crew Cab Chassis LS-M	Crew Cab Ute LS-M	Crew Cab Chassis LS-U	Crew Cab Ute LS-U	Crew Cab Ute LS-U+	Crew Cab Ute X-TERRAIN
Front bucket whiplash protection seats	●	●	●	●	●	●	●	●	●	●	●	●	●	●	●	●
6-way adjustable driver seat	●	●	●	●	●	●	●	●	●	●	●	●	●	●	●	●
8-way electric adjustable driver seat																
Electric adjustable lumbar support (driver seat only)					●			●					●	●	●	●
Heated front seats															●	●
Split-fold rear seat			●	●					●	●			●	●	●	●
Split-fold rear seat with centre arm rest					●						●	●	●	●	●	●
Rear centre seat headrest			●	●	●				●	●	●	●	●	●	●	●

Cabin Amenities

Dual zone climate control air-conditioning with integrated heater/demister					●			●					●	●	●	●
Manual air-conditioning with integrated heater/demister	●	●	●	●	●	●	●		●	●	●	●	●	●	●	●
Rear seat air-conditioning vents			●	●	●				●	●	●	●	●	●	●	●
Pollen and fine particle air filter	●	●	●	●	●	●	●	●	●	●	●	●	●	●	●	●
Power windows with one-touch up/down driver's window with safety stop and delay closing	●	●	●	●	●	●	●	●	●	●	●	●	●	●	●	●
Comfort turn signal	●	●	●	●	●	●	●	●	●	●	●	●	●	●	●	●
Central locking with keyless entry	●	●	●	●	●	●	●	●	●	●	●	●	●	●	●	●
Smart keyless entry					●			●					●	●	●	●
Walk away lock					●			●					●	●	●	●
Push button start					●			●					●	●	●	●
Remote engine start					●			●					●	●	●	●
Power-adjustable door mirrors with turn indicator lights					●			●			●	●	●	●	●	●
Power-adjustable door mirrors	●	●	●	●	●	●	●		●	●						
4 speaker sound system	●	●	●	●	●	●	●		●	●						
6 speaker sound system								●			●	●				
*Sky Sound™ roof-mounted sound system with 8 speakers (mounted in front dash, front doors, rear doors and roof)					●								●	●	●	●
9 inch touchscreen display with Apple CarPlay® and Android Auto™					●			●					●	●	●	●
7 inch touchscreen display with Apple CarPlay® and Android Auto™	●	●	●	●	●	●	●		●	●	●	●				
Built-in satellite navigation with MID turn-by-turn directions					●			●					●	●	●	●
Rear centre console USB charging port					●						●	●	●	●	●	●
Tilt and telescopic adjustable steering wheel with electric power steering	●	●	●	●	●	●	●	●	●	●	●	●	●	●	●	●
Urethane steering wheel with cruise, audio and voice recognition controls	●	●	●	●	●	●	●	●	●	●	●	●	●	●	●	●
Leather steering wheel with cruise, audio and voice recognition controls					●			●					●	●	●	●
Smart MID with digital speedometer, safety information, fuel economy and range, odometer, trip information and service reminder	●	●	●	●	●	●	●	●	●	●	●	●	●	●	●	●
Electro-luminescent gauges	●	●	●	●	●	●	●	●	●	●	●	●	●	●	●	●
*Terrain Command™ 4x4 select dial					●			●					●	●	●	●
Rear differential lock button					●			●					●	●	●	●
Automatic windshield wipers	●	●	●	●	●	●	●	●	●	●	●	●	●	●	●	●
Intuitive flat wiper blade					●			●					●	●	●	●
Day/night interior rear view mirror	●	●	●	●	●	●	●	●	●	●	●	●	●	●	●	●
Auto-dimming rear view mirror					●			●					●	●	●	●
Sun visors with vanity mirrors (driver and passenger) and ticket retaining strap (driver)					●			●					●	●	●	●
Sun visors with illuminated vanity mirrors (driver and passenger) and ticket retaining strap (driver)					●			●					●	●	●	●
Fixed A-pillar assist-grips for driver and front passenger	●	●	●	●	●	●	●	●	●	●	●	●	●	●	●	●
Fixed B-pillar assist-grips for rear passengers					●								●	●	●	●
Folding assist-grips for driver and front passenger					●								●	●	●	●
Folding assist-grips for rear passengers					●								●	●	●	●
Carpet flooring					●			●					●	●	●	●
Easy-clean vinyl flooring	●	●	●	●	●	●	●		●	●	●	●				

FUEL, WEIGHTS AND DIMENSIONS

D-MAX ADR 81/02^A Fuel Consumption Values

	4x2 High-Ride						4x4 ⁺										
	Single Cab Chassis SX	Space Cab Chassis SX	Crew Cab Chassis SX	Crew Cab Ute SX	Crew Cab Ute LS-U		Single Cab Chassis SX	Space Cab Chassis SX	Space Cab Ute LS-U	Crew Cab Chassis SX	Crew Cab Ute SX	Crew Cab Chassis LS-M	Crew Cab Ute LS-M	Crew Cab Chassis LS-U	Crew Cab Ute LS-U	Crew Cab Ute LS-U+	Crew Cab Ute X-TERRAIN
	1.9L	3.0L															
Transmission (MT = Manual, AT = Automatic)	MT/AT	MT/AT	AT	AT	AT	AT	MT / AT	MT / AT	AT	MT / AT	AT	AT	MT / AT	AT	MT / AT	AT	AT
FUEL CONSUMPTION (litres/100km)																	
Combined	7.0	8.0	8.0	8.0	7.7	8.0	8.0	8.0	8.0	8.0	8.0	7.7/8.0	8.0	7.7/8.0	8.0	8.0	8.0
Urban	8.1/7.9	10.2/9.8	9.8	9.8	9.5	9.8	10.2/9.8	10.2/9.8	9.8	9.8	9.8	9.7/9.8	9.8	9.7/9.8	9.8	9.8	9.8
Extra Urban	6.5/6.6	6.7/6.9	6.9	6.9	6.7	6.9	6.7/6.9	6.7/6.9	6.9	6.9	6.9	6.6/6.9	6.9	6.6/6.9	6.9	6.9	6.9
CO² (g/km)																	
Combined	183/184	206/207	207	207	200	207	206/207	206/207	207	206/207	207	200/207	207	200/207	207	207	207
Urban	212/208	262/254	254	254	246	254	262/254	262/254	254	262/254	254	251/254	254	251/254	254	254	254
Extra Urban	170/174	174/180	180	180	174	180	174/180	174/180	180	174/180	180	171/180	180	171/180	180	180	180

Dimensions (mm unless stated otherwise)

Wheelbase	3125	3125	3125	3125	3125	3125	3125	3125	3125	3125	3125	3125	3125	3125	3125	3125	3125
Overall length	5325	5285	5285	5265	5270	5270	5325	5285	5270	5285	5265	5285	5270	5270	5303	5303	5303
Overall width (excluding door mirrors)	1870	1870	1870	1870	1870	1870	1870	1870	1870	1870	1870	1870	1870	1870	1870	1870	1880
Overall height (*depends on body fitted)	1790*	1800*	1800*	1785	1790	1790	1790*	1800*	1790	1800*	1785	1800*	1785	1805*	1790	1790	1810
Front overhang	890	890	890	890	890	890	890	890	890	890	890	890	890	890	890	890	905
Rear overhang (*depends on body fitted)	1310*	1270*	1270*	1250	1250	1250	1310*	1270*	1250	1270*	1250	1270*	1250	1270*	1250	1250	1250
Wheel track width	1570	1570	1570	1570	1570	1570	1570	1570	1570	1570	1570	1570	1570	1570	1570	1570	1570
Ground clearance	235	235	235	235	240	240	235	235	240	235	235	235	235	240	240	240	240
Turning circle diameter between kerbs (metres)	12.5	12.5	12.5	12.5	12.5	12.5	12.5	12.5	12.5	12.5	12.5	12.5	12.5	12.5	12.5	12.5	12.5
Approach angle	29.6°	29.6°	29.6°	30°	30.5°	30.5°	29.6°	29.6°	30.5°	29.6°	30°	29.6°	30°	30°	30.5°	30.5°	30.5°
Departure angle	24.6°	25.3°	25.3°	23.9°	19.0°	19.0°	24.6°	25.3°	19.0°	25.3°	23.9°	25.3°	23.9°	20.6°	19.0°	19.0°	19.0°
Ramp-over angle	23.9°	23.9°	23.9°	23.3°	23.8°	23.8°	23.9°	23.9°	23.8°	23.9°	23.3°	23.3°	23.3°	24.3°	23.8°	23.8°	23.8°

Load area (mm)

Cab to rear axle	1240	765	450	450	450	450	1240	765	765	450	450	450	450	450	450	450	450
Length (top)	-	-	-	1495	1495	1495	-	-	1805	-	1495	-	1495	-	1495	1495	1495
Length (floor) (*inside genuine accessory tray body)	2550*	2100*	1800*	1570	1570	1570	2550*	2100*	1835	1800*	1570	1800*	1570	1800*	1570	1570	1570
Maximum width (*inside genuine accessory alloy tray body)	1777*	1777*	1777*	1530	1530	1530	1777*	1777*	1530	1777*	1530	1777*	1530	1777*	1530	1530	1530
Width between wheel houses	-	-	-	1122	1122	1122	-	-	1122	-	1122	-	1122	-	1122	1122	1122
Depth	-	-	-	490	490	490	-	-	490	-	490	-	490	-	490	490	490

Interior (mm)

Leg room - front	1075	1075	1075	1075	1075	1075	1075	1075	1075	1075	1075	1075	1075	1075	1075	1075	1075
Leg room - rear	-	-	905	905	905	905	-	-	-	905	905	905	905	905	905	905	905
Shoulder room - front	1460	1460	1460	1460	1460	1460	1460	1460	1460	1460	1460	1460	1460	1460	1460	1460	1460
Head room - front	1020	1020	1020	1020	1020	1020	1020	1020	1020	1020	1020	1020	1020	1020	1020	1020	1020
Rear cargo space	-	730	-	-	-	-	-	730	730	-	-	-	-	-	-	-	-

Mass (kg)

Gross Vehicle Mass (GVM)	3000	3000	3000	3000	3000	3000	3100	3100	3100	3100	3100	3100	3100	3100	3100	3100	3100
Kerb weight [†]	1595/1620	1695/1700	1770	1825	1945	2015	1780/1790	1850/1860	2060	1900/1910	2035	1905	2020/2030	1960	2100/2105	2112	2165
Payload [‡] (cab chassis models: final mass depends on body fitted)	1405/1380	1305/1300	1230	1175	1055	985	1320/1310	1250/1240	1040	1200/1190	1065	1195	1080/1070	1140	1000/995	988	935
Gross Combination Mass (GCM)	5300/5500	5850	5850	5850	5850	5850	6000	6000	6000	6000	6000	5950	6000	6000	6000	6000	6000
Maximum towing mass (braked trailer)	2800/3000	3500	3500	3500	3500	3500	3500	3500	3500	3500	3500	3500	3500	3500	3500	3500	3500
Maximum towing mass (non-braked trailer)	750	750	750	750	750	750	750	750	750	750	750	750	750	750	750	750	750
Maximum tow ball download (when fitted with genuine Isuzu UTE tow kit)	280/300	350	350	350	350	350	350	350	350	350	350	350	350	350	350	350	350
Fuel tank capacity (litres)	76	76	76	76	76	76	76	76	76	76	76	76	76	76	76	76	76

[†]Fuel consumption & emissions figures based on ADR 81/02 & are to be used for vehicle comparison purposes only. Actual fuel consumption & emissions will vary depending on many factors including, but not limited to, traffic conditions, individual driving style & vehicle condition.
[‡]Kerb weight - unladen mass of vehicle & full tank of fuel, excludes tray body for cab chassis vehicles. Fuel weight ratio is based on Fuel Standard (Automotive Diesel) Determination 2001. ^{††}Payload equals GVM minus kerb weight. ^{†††}Limited stock available on these models. Please contact your local Isuzu UTE Dealer for more information.

CAB CHASSIS BODY STYLES AND DIMENSIONS (22MY)



SX Single Cab Chassis 4x2 & 4x4



SX Space Cab Chassis 4x2 & 4x4



SX Crew Cab Chassis 4x2 & 4x4



LS-M Crew Cab Chassis 4x4

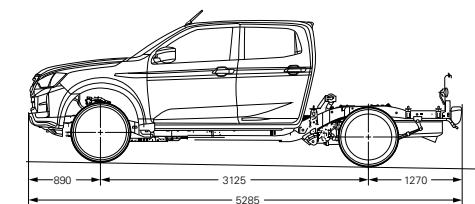
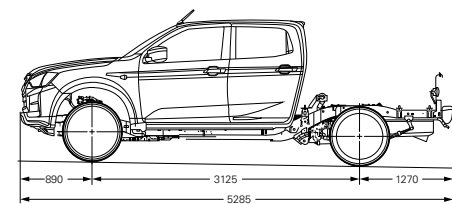
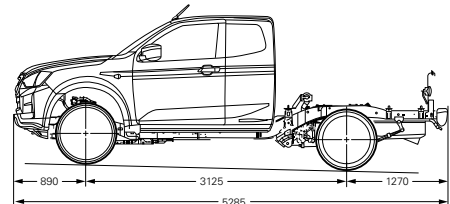
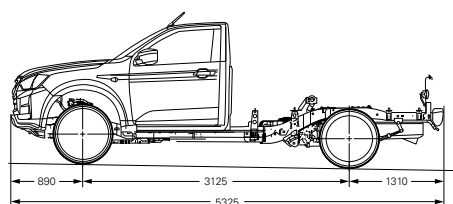
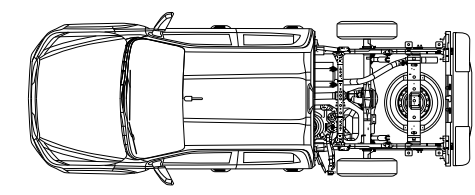
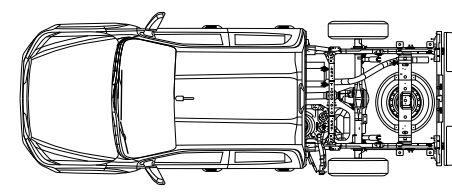
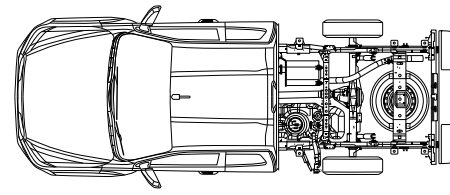
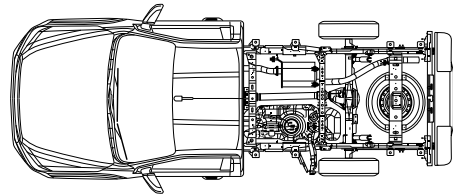
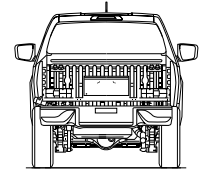
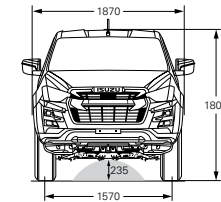
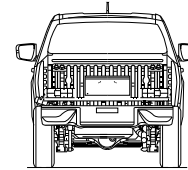
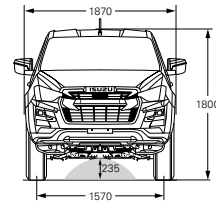
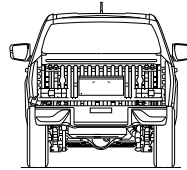
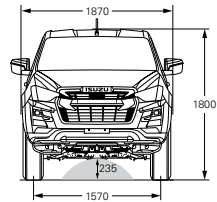
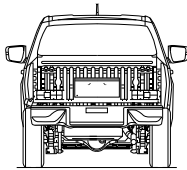
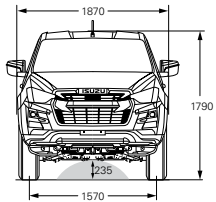

CAB CHASSIS AND UTE BODY STYLES AND DIMENSIONS (22MY)



LS-U Crew Cab Chassis 4x4



SX Crew Cab Ute 4x2 & 4x4



LS-M Crew Cab Ute 4x4

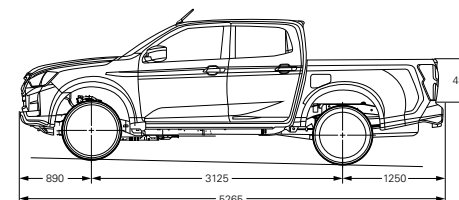
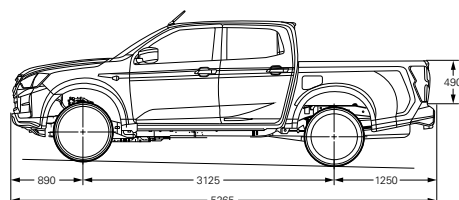
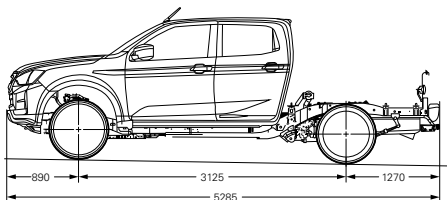
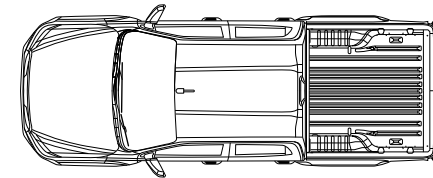
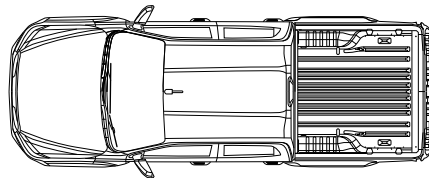
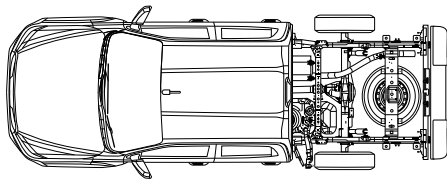
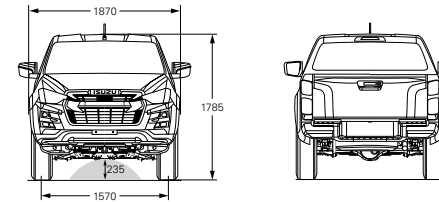
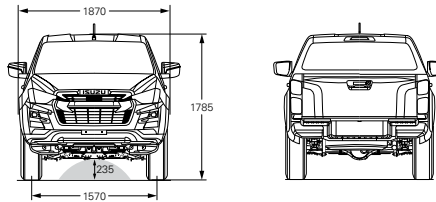
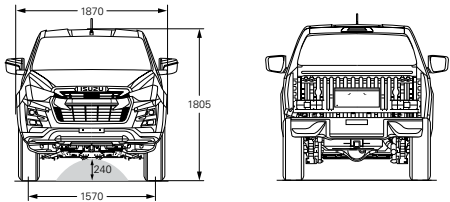

UTE BODY STYLES AND DIMENSIONS (22MY)



LS-U Space Cab Ute 4x4

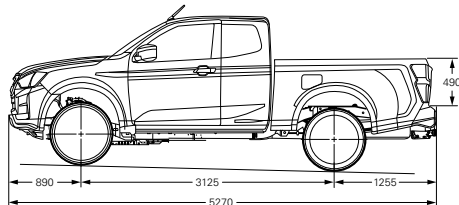
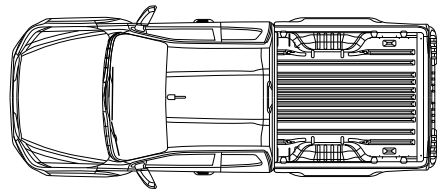
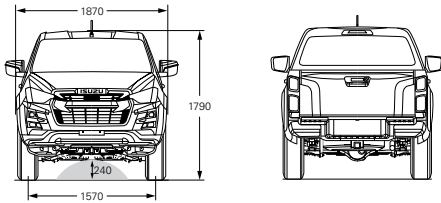

**LS-U Crew Cab Ute 4x2 & 4x4
LS-U+ Crew Cab Ute 4x4**

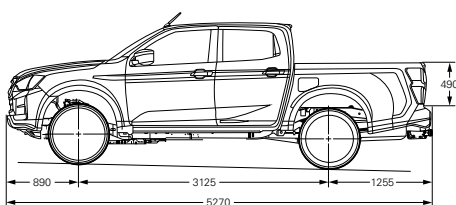
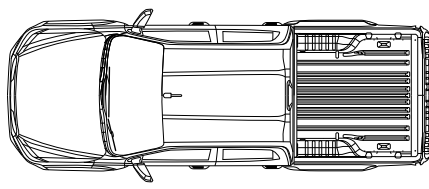
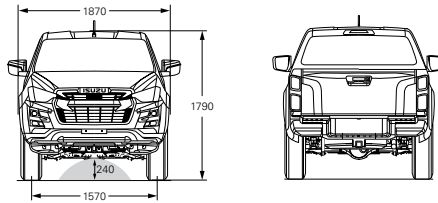

X-TERRAIN Crew Cab Ute 4x4

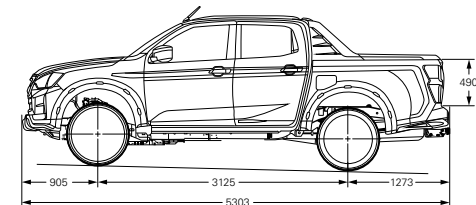
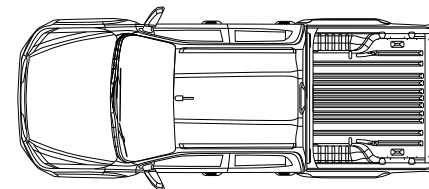
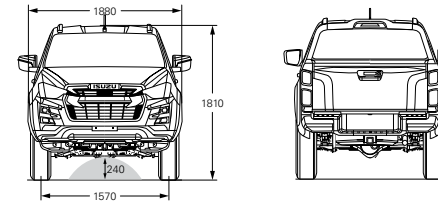

COLOURS AND TRIM (22MY)

Body Colours



Basalt Black mica



Cobalt Blue mica



Mercury Silver metallic



Obsidian Grey mica



Mineral White



Marble White pearl
(LS-U Range & X-TERRAIN Exclusive)



Magnetic Red mica
(LS-U Range & X-TERRAIN Exclusive)



Volcanic Amber metallic
(X-TERRAIN Exclusive)

Interior Trim



Standard Black Cloth
(On SX models)



High Grade Cloth
(On LS-M & LS-U models)



Leather Accented*
(On LS-U+)



Leather Accented* with Red Stitching
(On X-TERRAIN)

*Seats have leather touches or accents, but are not wholly leather.

TRAY STYLES

Economy Alloy

General Purpose Alloy

Heavy Duty Alloy

Heavy Duty Steel

Mine Specification Steel



Single



Space



Crew





ISUZU
UTE

GO YOUR OWN WAY

BROOKS
EQUIPMENT

Authorised Dealers for



1300 BROOKS (1300 276 657)

@ sales@brooksequipment.com.au

www.brooksequipment.com.au