

BROOKS

EQUIPMENT

Phone: 1300 276 657

Email: service@brooksequipment.com.au

www.brooksequipment.com.au

ISO 14001
BUREAU VERITAS
Certification



AS/NZS 4801
BUREAU VERITAS
Certification



ISO 9001
BUREAU VERITAS
Certification



Designed for the most demanding conditions

Portable screw compressors



CompAir



Reliable mobile compressed air solutions



CompAir Portable Compressors

Designed for the most demanding conditions. High-precision construction projects demand that the efficiency and reliability of compressors is of the highest calibre. CompAir offers a wide range of portable compressors, with a reputation within the industry for just that - compressors that meet the requirements of numerous mobile compressed air applications.

The C-Series from CompAir is constantly evolving and guarantees high energy efficiency, low emissions and many other innovations, which make daily operations and maintenance tasks much easier.

Engineering Excellence

Changing emission legislation is a key driver for development, but CompAir's passionate engineering team also strive to achieve the best possible performance at the lowest operational costs. Additionally, the compressors are very compact and lightweight which is a preference for many customers.

The screw compression element is the most important component of the compressor. Therefore CompAir keeps the design and manufacture in-house, using the latest CNC rotor grinding machinery, coupled with online laser technology. The resulting reliability and performance ensures that operating costs will remain low throughout the life of the compressor.



CompAir Genuine Parts

Enjoy complete peace of mind. Genuine CompAir parts and lubricants ensure best performance and reliability is maintained.

- Minimum losses contributing to energy savings
- Long service life, even under harsh conditions
- High reliability



AirPlus

Tailored compressor solutions to fit your application. CompAir offers numerous options and accessories allowing customers to configure the compressor according to the specific requirements of the application. Besides various components for air treatment, integrated generators, bundled bottom boxes, toolboxes, hose reels and integrated oilers, etc. can all be factory fitted.

Performance Protection for Portable Compressors

When you buy a CompAir C-Series portable compressor, peace of mind comes as standard now. The first of a kind Mobile 5 Warranty offers genuine performance protection for up to 5 years. The main compressor elements and controls are covered at zero additional cost.

Having your compressor serviced by authorised personnel in accordance with CompAir's maintenance schedules, ensures you enjoy comprehensive protection for up to 5 years (up to a maximum of 10,000 operating hours).

Mobile 5 from CompAir - keeping your workforce working.

Terms, conditions & exclusions apply.



Contact
Nathan Fenemer - 0438 631 952
nfenemer@brooksequipment.com.au



C35-10 to C50

3.5 to 5.0 m³/min

Product range

DLT 0408



These proven and tested compressors stand out for their low fuel consumption and high efficiency. Thanks to a wide pressure range up to 14 bar, this compact compressor range is extremely versatile and meets many requirements of numerous applications. The compressors have enough storage capacity for two hammers, picks or any other pneumatic tools. Separate engine and compressor air filters guarantee a long service life. All of the service points are strategically located for easy access.

Soft Start

Extends the engine lifetime by reducing engine stress during start-up and allowing the engine to reach running temperature with the compressor unloaded.

Bolted Single Sheets

The steel canopy is galvanised and electrostatically coated, offering excellent protection against damage and corrosion. With bolted single sheets, exchange is both quick and easy.

Easy Access Hinged Hood

With two robust gas struts, the hood is light and easy to open, offering excellent accessibility for easy maintenance.

Cummins B3.3TAA

Quiet-running and low vibration 4-cylinder diesel engine.

Robust Plastic Protection

Protects the control panel and lighting elements.

Filtration

According to ZTV-ING part 3 section 4.

Fuel Filter

Fuel contamination is controlled by high quality filter which includes water separation. In addition to this every compressor has a manual fuel pump as standard.

Air Filters

Separate air filters for engine and air compressor.

Progressive Volume Flow Regulation

Engine speed and air intake regulation are automatically adapted to compressed air requirement.

Air End With Spin-On Oil Filter Cartridge

For quick and easy maintenance.

Internal Main Switch Board

To avoid unauthorised operation.

Central Lifting Eye

For easy handling by crane.

Transparent Plastic Fuel Tank

Allows direct visual level indication and quick contamination checks.

Operational Reliability

Designed for - 10 to + 45° C ambient temperature.

Oil Temperature Regulation Valve

Ensures safe operation of compressor at low ambient temperatures or extreme partial load.

Portable-Control 2+

- Fully protected digital display
 - With tamper proof hour counter
- Indication lamps
 - For automatic emergency stop in case of malfunction
- Automatic protection in case of malfunction:
 - Compressor temperature too high
 - Engine oil pressure too low
 - Engine temperature too high
 - Battery voltage too low
 - Fuel level too low
- Start by rotary switch
 - To avoid loss of time caused by lost ignition key



BROOKS
EQUIPMENT

Contact

Nathan Fenemer - 0438 631 952

nfenemer@brooksequipment.com.au

Technical Data - C35-10 to C50

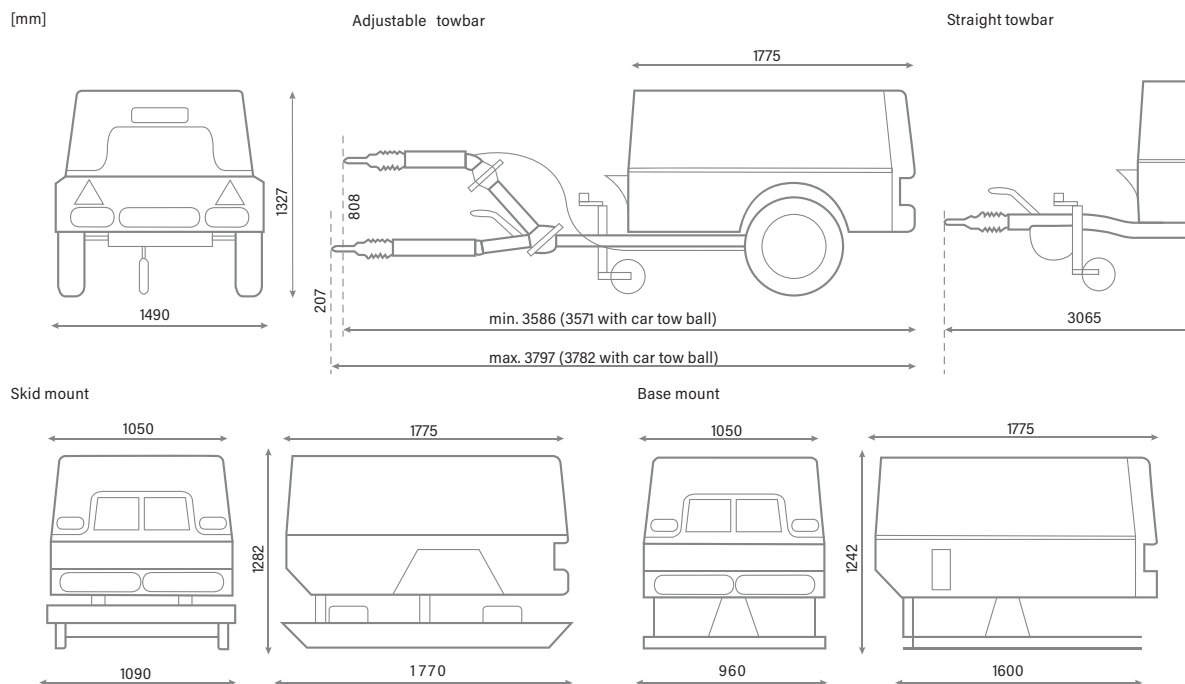

Product range		DLT 0408				
Type		C35-10	C38	C42	C50	
Operational data						
Volume flow ¹⁾	m ³ /min	3.5	3.8	4.2	5.0	
(Optional 9 or 15 kVA Generator)	cfm	123.6	134	148	176.5	
Working pressure	bar	10	7	7	7	
	psi	145	101.5	101.5	101.5	
Engine		Yanmar 4TNV88BKCP				
Installed engine power	kW	35.0	35.0	35.0	35.0	
RPM-range	1/min	1600 - 2800	1600 - 2800	1600 - 2800	1600 - 2800	
Operating weight ²⁾						
Portable compressor	adjustable towbar braked	kg	810	810	810	866
	adjustable towbar unbraked	kg	745	745	745	-
	straight towbar braked	kg	775	775	775	835
	straight towbar unbraked	kg	740	740	740	800
Base mount	kg	685	685	685	780	
Skid mount	kg	740	740	740	800	
Filling capacities						
Engine oil	l	7.4	7.4	7.4	7.4	
Diesel tank	l	60	60	60	60	
Compressor oil	l	9	9	9	9	
Dimensions and connections						
Length	adjustable towbar braked	mm	3586 - 3797	3586 - 3797	3586 - 3797	3586 - 3797
	straight towbar braked	mm	3065	3065	3065	3065
Width	mm	1490	1490	1490	1490	
Height (adjustable towbar, braked)	mm	1327	1327	1327	1327	
Compressed air outlet	2 x 3/4"					
Sound level						
Sound pressure level ³⁾	dB(A) LPA	69	69	69	69	

¹⁾ Acc. to ISO 1217 Ed. 4 2009 Annex D

²⁾ Operating weight without options

³⁾ Noise level acc. to PNEUROP PN8NTC.2.2 at 7 m



C55-14 to C76

5.5 to 7.6 m³ / min

Product range

DLT 0704



These proven and tested compressors stand out for their low fuel consumption and high efficiency. Thanks to a wide pressure range up to 14 bar, this compact compressor range is extremely versatile and meets many requirements of numerous applications. The compressors have enough storage capacity for two hammers, picks or any other pneumatic tools. Separate engine and compressor air filters guarantee a long service life. All of the service points are strategically located for easy access.

Soft Start

Extends the engine lifetime by reducing engine stress during start-up and allowing the engine to reach running temperature with the compressor unloaded.

Bolted Single Sheets

The steel canopy is galvanised and electrostatically coated, offering excellent protection against damage and corrosion. With bolted single sheets, exchange is both quick and easy.

Easy Access Hinged Hood

With two robust gas struts, the hood is light and easy to open, offering excellent accessibility for easy maintenance.

Cummins B3.3TAA

Quiet-running and low vibration 4-cylinder diesel engine.

Robust Plastic Protection

Protects the control panel and lighting elements.

Filtration

According to ZTV-ING part 3 section 4.

Fuel Filter

Fuel contamination is controlled by high quality filter which includes water separation. In addition to this every compressor has a manual fuel pump as standard.

Air Filters

Separate air filters for engine and air compressor.

Progressive Volume Flow Regulation

Engine speed and air intake regulation are automatically adapted to compressed air requirement.

Air End With Spin-On Oil Filter Cartridge

For quick and easy maintenance.

Internal Main Switch Board

To avoid unauthorised operation.

Central Lifting Eye

For easy handling by crane.

Transparent Plastic Fuel Tank

Allows direct visual level indication and quick contamination checks.

Operational Reliability

Designed for - 10 to + 45° C ambient temperature.

Oil Temperature Regulation Valve

Ensures safe operation of compressor at low ambient temperatures or extreme partial load.

Portable-Control 2+

- Fully protected digital display
 - With tamper proof hour counter
- Indication lamps
 - For automatic emergency stop in case of malfunction
- Automatic protection in case of malfunction:
 - Compressor temperature too high
 - Engine oil pressure too low
 - Engine temperature too high
 - Battery voltage too low
 - Fuel level too low
- Start by rotary switch
 - To avoid loss of time caused by lost ignition key



BROOKS
EQUIPMENT

Contact

Nathan Fenemer - 0438 631 952

nfenemer@brooksequipment.com.au

Technical Data - C55-14 to C76

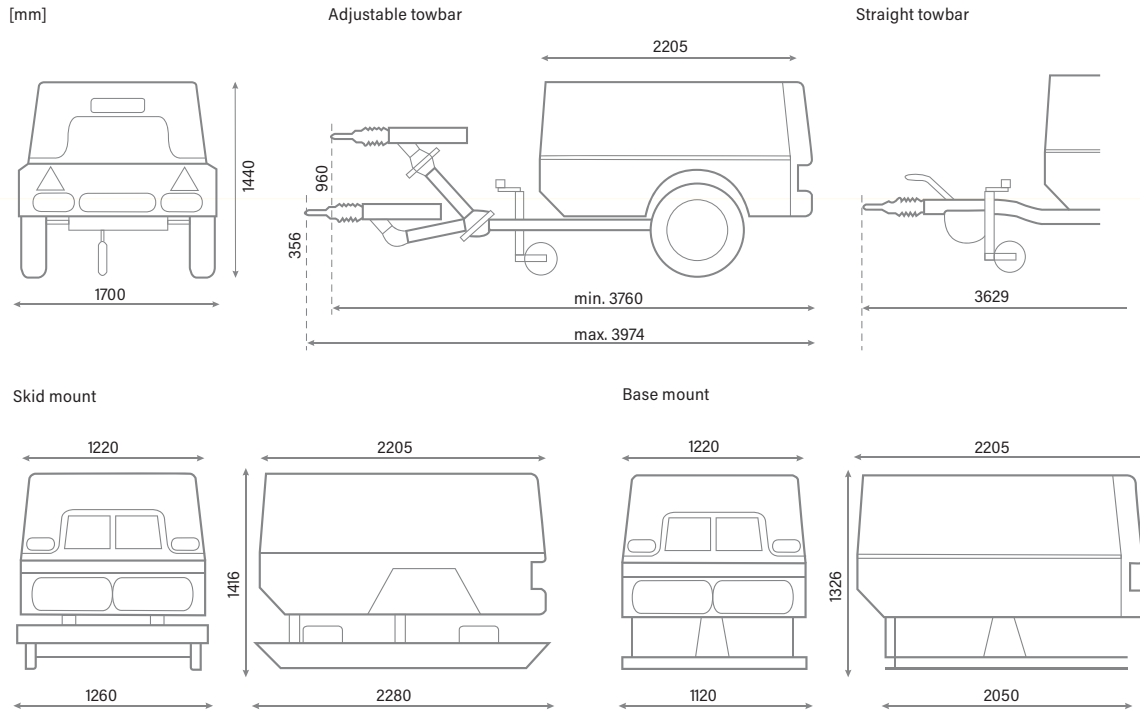

Product range		DLT 0704				
Type		C55-14	C60-12	C65-10	C65HS	C76
Operational data						
Volume flow ¹⁾	m ³ / min	5.5	6.0	6.5	6.5	7.6
(Optional 9 or 15 kVA Generator)	cfm	194	211.9	229.5	229.5	268
Working pressure	bar	14	12	10	7	7
	psi	203	174	145	101.5	101.5
Engine		Cummins B3.3 TAA				
Installed engine power	kW	63	63	63	63	63
RPM range	1/min	1 600 - 2600	1 600 - 2600	1 600 - 2600	1 600 - 2600	1 600 - 2600
Operating weight ²⁾						
Portable compressor	adjustable towbar braked	kg	1200	1200	1200	1200
	straight towbar braked	kg	1160	1160	1160	1160
Base mount	kg	1070	1070	1070	1070	1070
Skid mount	kg	1100	1100	1100	1100	1100
Filling capacities						
Engine oil	l	8	8	8	8	8
Diesel tank	l	140	140	140	140	140
Compressor oil	l	17.5	17.5	17.5	17.5	17.5
Dimensions and connections						
Length	adjustable towbar braked	mm	3760 - 3974	3760 - 3974	3760 - 3974	3760 - 3974
	straight towbar braked	mm	3629	3629	3629	3629
Width	mm	1700	1700	1700	1700	1700
Height	mm	1440	1440	1440	1440	1440
Compressed air outlet	3 x 3/4", optionally 1 x 1/2"					
Sound level						
Sound pressure level ³⁾	dB(A) LPA	71	71	71	71	71

¹⁾ Acc. to ISO 1217 Ed. 4 2009 Annex D

²⁾ Operating weight without options

³⁾ Noise level acc. to PNEUROP PN8NTC2.2 at 7 m



C85-14 to C140-9

8.5 to 13.3 m³ / min

Product range

DLT 1302



Designed for the toughest site conditions, whether it's for road building, civil engineering or restoration work, this range of compressors offers outstanding reliability, performance and compressed air quality. With fully accessible doors, maintenance is also made easy. The compressor as standard is equipped with numerous options, offering a substantial cost saving to the customer. Thanks to the inclusion of two batteries, reliable running and performance can be achieved even in cold conditions. The long life cycle of these compressors is further enhanced by additional engine management protection. Diesel engines from the QSB 4.5 range from Cummins are fitted with electronic fuel injection to meet the European exhaust emission standards.

Soft Start

Extends the engine lifetime by reducing engine stress during start-up and allowing the engine to reach running temperature with the compressor unloaded.

Easy Access Side Wing Doors

Offering excellent accessibility for easy maintenance.

Air Filters

Separate air filters for engine and air compressor.

Cummins Engine

Quiet-running 4-cylinder diesel engine.

Robust Plastic Protection

Protects the control panel and lighting elements.

Sheet Steel Fuel Tank

With direct visual level indication.

Fuel Filter

Fuel contamination is controlled by high quality filter which includes water separation. In addition to this every compressor has a manual fuel pump as standard.

Progressive Volume Flow Regulation

Engine speed and air intake regulation are automatically adapted to compressed air requirement.

Air End With Spin-On Oil Filter Cartridge

For quick and easy maintenance.

Internal Main Switch Board

To avoid unauthorised operation.

Central Lifting Eye

For easy handling by crane.

Operational Reliability

Designed for - 10 to + 45° C ambient temperature.

Oil Temperature Regulation Valve

Ensures safe operation of compressor at low ambient temperatures or extreme partial load.

Instrument Panel

With clearly visible instruments, as well as individual fault indicators, such as battery pilot lamp and warming-up button. The panel uses a robust relay switching system with plug-in relays in a closed circuit system to fully protect the complete unit. The instrument panel is protected against vandalism by a strong lockable steel enclosure.



BROOKS
EQUIPMENT

Contact

Nathan Fenemer - 0438 631 952

nfenemer@brooksequipment.com.au

Technical Data - C85-14 to C140-9

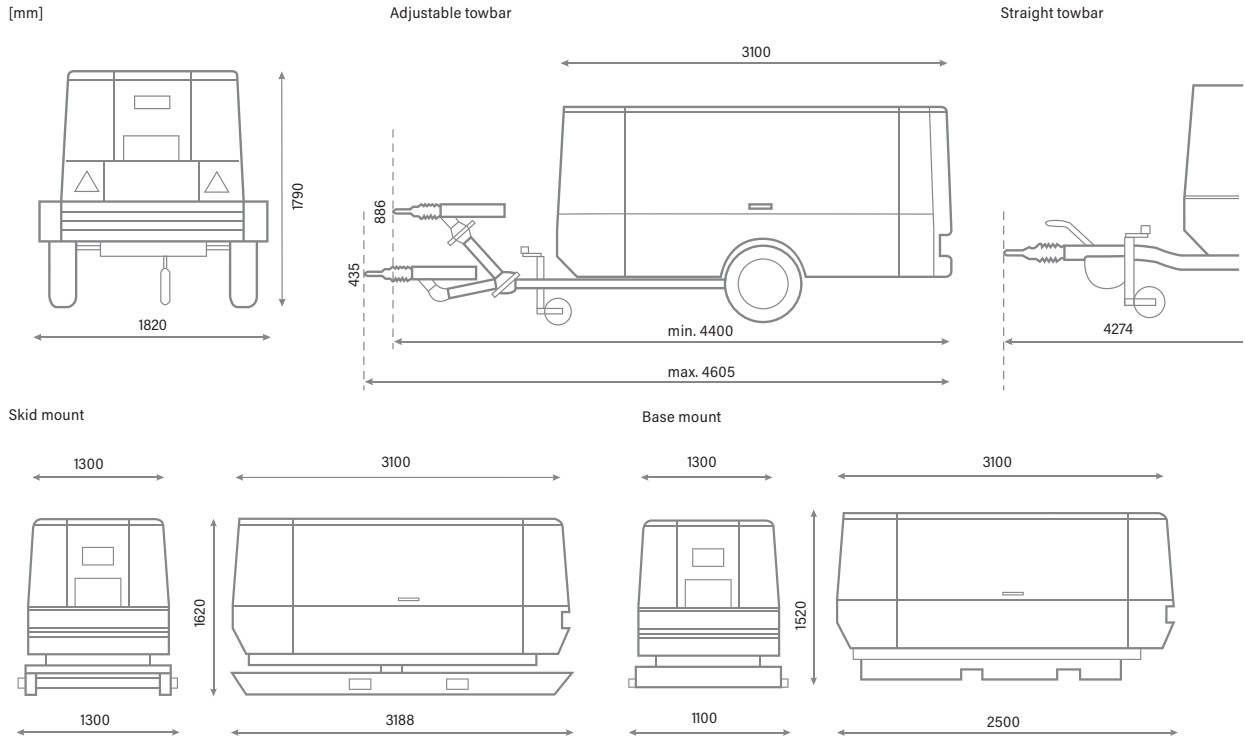

Product range		DLT 1303						
Type		C85-14	C95-12	C110-9	C125	C105-14	C115-12	C140-9
Operational data								
Volume flow ¹⁾	m ³ / min	8.5	9.5	11.3	12.5	10.5	11.5	13.3
	cfm	300	335	388	441	370.8	406	469.6
Operating pressure	bar	14	12	8.6	7	14	12	8.6
	psi	203	174	124.7	101.5	203	174	124.7
Engine		Cummins QSB 4.5				Cummins QSB 4.5		
Installed engine power		97	97	97	97	11 9	11 9	11 9
RPM-range	1/ min	1300 - 2300	1300 - 2300	1300 - 2300	1300 - 2300	1300 - 2200	1300 - 2200	1300 - 2200
Operating weight ²⁾								
Portable compressor								
	adjustable towbar braked kg	1980	1980	1980	1980	1980	1980	1980
	straight towbar braked kg	1950	1950	1950	1950	1950	1950	1950
Base mount	kg	18 10	18 10	18 10	18 10	18 10	18 10	18 10
Skid mount	kg	19 20	19 20	19 20	19 20	19 20	19 20	19 20
Filling capacities								
Engine oil	l	11	11	11	11	11	11	11
Diesel tank	l	210	210	210	210	210	210	210
Compressor oil	l	24	24	24	24	24	24	24
Dimensions and connections								
Length	adjustable towbar braked mm	4390-4555	4390-4555	4390-4555	4390-4555	44390-4555	4390-4555	4390-4555
	straight towbar braked mm	4274	4274	4274	4274	4274	4274	4274
Width	mm	1820	1820	1820	1820	1820	1820	1820
Height	mm	1790	1790	1790	1790	1790	1790	1790
Compressed air outlet		2 x 3/4" and 1 x 2"						
Sound level								
Sound pressure level ³⁾	dB(A) LPA	70	70	70	70	70	70	70

¹⁾ Acc. to ISO 1217 Ed. 4 2009 Annex D

²⁾ Operating weight without options

³⁾ Noise level acc. to PNEUROP PN8NTC.2.2 at 7 m

AirPlus - Many Options for Many Applications

Options for all types of C10-12 to C270TS-9



Breakers



Sand-blasting

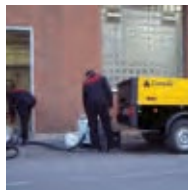

Ice-blasting



Drillings



Concrete spraying

AirPlus Options



Built-in aftercooler

With automatic water separation. Reduces water content in the compressed air. An additional heat exchanger uses compressor oil to heat the compressed air which protects the tools from freezing.



Integrated Oiler

For optimised lubrication of the pneumatic tools.

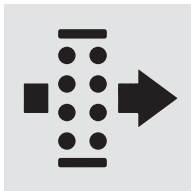

Built-in microfilter combination

(in addition to above mentioned aftercooler)
Air treatment with microfilters according to ISO 8573.1 standards including ZTV-ING 90 with residual oil content of <0.01 ppm.



Hose reel

With 20m light self-supporting hose; protects the air hose and enables fast set up of tools at site.

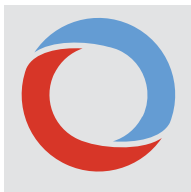

Oil temperature regulation valve

Ensures safe operation of compressor at low ambient temperatures. Prevents compressed air tools from freezing. Standard from C35-10.



Special paint colour and labelling

to customer specification
Provides distinctive site identity and assists in traceability in the event of loss or theft.

Schematic display of all available air treatment options

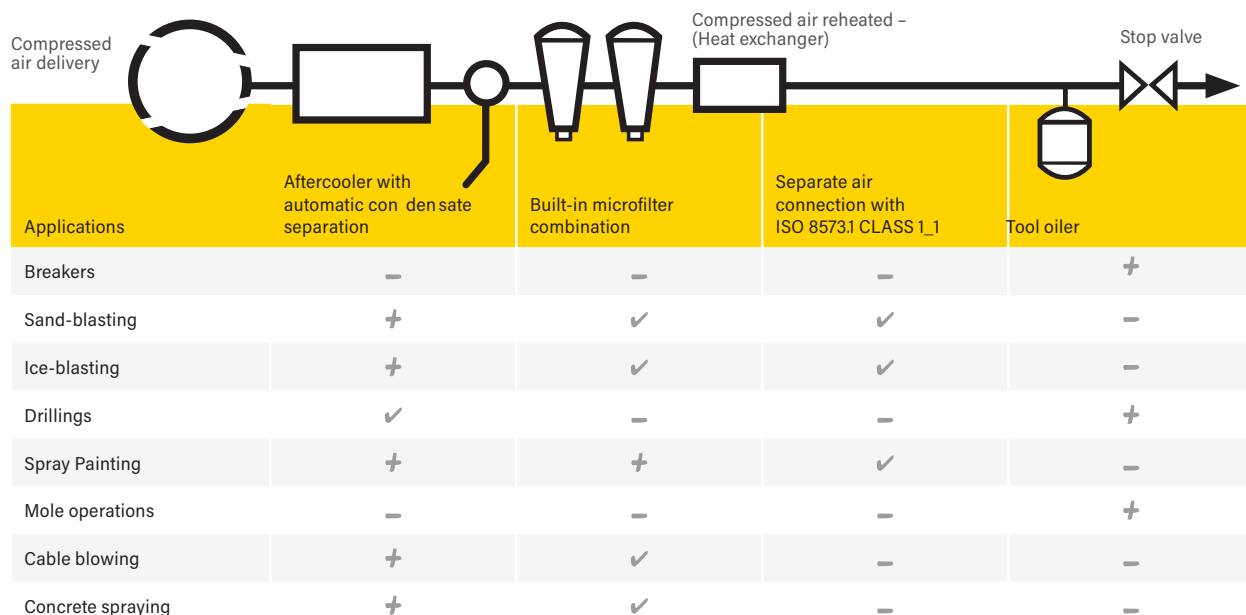

+ recommended ✓ depending on manufacturer and application - not needed

AirPlus - Many Options for Many Applications

Options for all types of C14 to C270TS-9

+ Optional ✓ Standard - Not available

Type	Compressed Air Quality			Compressor Equipment				Integrated Generator			Engine Accessories			
	Aftercooler	Filtration	Oiler	Tool-Box	Hose reel	Bundled bottom box	Oil thermostatic valve	7 kVA at 110V 50Hz	9 kVA/16 A max. at 230/400V 50Hz	15 kVA/20 A max. at 230/400V 50 Hz	Diesel filter with water separator	Spark arrestor	Engine shutdown at overspeed from flammable gases	Remote start / stop
DLT 0101														
C10-12	-	-	+	-	-	-	-	-	-	-	-	-	-	-
C12-10	-	-	+	-	-	-	-	-	-	-	-	-	-	-
C14	-	-	+	-	-	-	-	-	-	-	-	-	-	-
DLT 0206														
C20	+	-	+	+	+	+	✓	+	+	-	✓	+	+	-
C25	+	-	+	+	+	+	✓	-	-	-	✓	+	+	-
C30	+	-	+	+	+	+	✓	+	+	-	✓	+	+	-
DLT 0408														
C35-10	+	+	+	+	+	+	✓	+	+	+	✓	+	+	-
C38	+	+	+	+	+	+	✓	+	+	+	✓	+	+	-
C42	+	+	+	+	+	+	✓	+	+	+	✓	+	+	-
C50	+	+	+	+	+	+	✓	+	+	+	✓	+	+	-
DLT 0704														
C55-14	+	+	+	+	+	+	✓	+	+	+	✓	+	+	-
C60-12	+	+	+	+	+	+	✓	+	+	+	✓	+	+	-
C65-10	+	+	+	+	+	+	✓	+	+	+	✓	+	+	-
C76	+	+	+	+	+	+	✓	+	+	+	✓	+	+	-
DLT 1302														
C85-14	+	+	+	-	+	-	✓	-	-	-	✓	+	-	+
C95-12	+	+	+	-	+	-	✓	-	-	-	✓	+	-	+
C110-9	+	+	+	-	+	-	✓	-	-	-	✓	+	-	+
C125	+	+	+	-	+	-	✓	-	-	-	✓	+	-	+
C105-14	+	+	+	-	+	-	✓	-	-	-	✓	+	-	+
C115-12	+	+	+	-	+	-	✓	-	-	-	✓	+	-	+
C140-9	+	+	+	-	+	-	✓	-	-	-	✓	+	-	+
DLT 2701														
C200TS-14	+	+	+	-	-	-	✓	-	-	-	✓	+	-	+
C210TS-12	+	+	+	-	-	-	✓	-	-	-	✓	+	-	+
C220TS-10	+	+	+	-	-	-	✓	-	-	-	✓	+	-	+
C230TS-9	+	+	+	-	-	-	✓	-	-	-	✓	+	-	+
C240TS-14	+	+	+	-	-	-	✓	-	-	-	✓	+	-	+
C250TS-12	+	+	+	-	-	-	✓	-	-	-	✓	+	-	+
C260TS-10	+	+	+	-	-	-	✓	-	-	-	✓	+	-	+
C270TS-9	+	+	+	-	-	-	✓	-	-	-	✓	+	-	+
C200TS-24	-	-	-	-	-	-	✓	-	-	-	✓	+	-	+
C210TS-21	-	-	-	-	-	-	✓	-	-	-	✓	+	-	+
C230TS-17	-	-	-	-	-	-	✓	-	-	-	✓	+	-	+

- Electronic Controller
 - Insulation monitoring
 - Output voltage regulation
 - Temperature regulation limit
 - Two mode switch - constant and variable motor speed
- Integrated Generator
 - Electronically controlled synchronous generator
 - Protection IP 54
- Winter Kit ❄️
 - Available for selected models



Contact
 Nathan Fenemer - 0438 631 952
 nfenemer@brooksequipment.com.au

Global experience - truly local service

With over 200 years of engineering excellence, the CompAir brand offers an extensive range of highly reliable, energy efficient compressors and accessories to suit all applications. An extensive network of dedicated CompAir sales companies and distributors across all continents provide global expertise with a truly local service, ensuring our advanced technology is backed up with the right support.



As part of the worldwide Gardner Denver operation, CompAir has consistently been at the forefront of compressed air systems development, culminating in some of the most energy efficient and low environmental impact compressors on the market today, helping customers achieve or surpass their sustainability targets.

Portable Compressors (EU & Non EU Range)

C10-12 - C270TS-9

1 to 27 m³/min from 7 to 24 bar

Air Plus offers many variations

and options:

- Aftercooler
- Ultra-fine filters
- Integrated generator
- Bunded bottom box
- Hose reel
- Exhaust spark arrestor
- Exhaust gas particulate filter
- Customer colours

Services

- Technical support and advice
- Worldwide servicenetwork
- Reliable supply of spare parts
- Individual customersolutions
- Seminars and trainings



**2 YEAR
GUARANTEE**

BROOKS
EQUIPMENT

Nathan Fenemer - 0438 631 952
nfenemer@brooksequipment.com.au
www.brooksequipment.com.au