

# CONTAINER REACH STACKER



## REACH STACKER **XCS4531K**

Product Specifications

OVERALL WEIGHT  
**71,200 kg**

RATED CAPACITY  
**45,000 kg**

MAX. LIFTING HEIGHT  
**15,375 mm**

ENGINE  
**Cummins QSM 11**

### STANDARD EQUIPMENT

- **SPREADER:** XCMG spreader is suitable for handling 20' and 40' standard containers. Telescoping, side shift and rotating function, as well as twist lock control are available.  
Rated lifting capacity: 45 t.  
Side shift:  $\pm 800$  mm.  
Rotation angle:  $-105^{\circ} \sim +195^{\circ}$ .
- **CAB:** Dynamic moving full-view driver's cab. Equipped with ergonomic seat, two point retractable seat belt, water cup holder, 12V and 24V power supply, radio, loudspeaker amplifiers and HD reverse view system.
- **ENGINE:** QSM 11, in line, six-cylinder, water-cooled, turbocharged, electric control diesel engine manufactured by Cummins. Rated power 250 kW/2100rpm, max. torque 1674 Nm / 1400 rpm; Emission compliance: compliant with off-road U.S. EPA Tier 3/EU Stage IIIA.
- **TRANSMISSION:** 15.5HR36432, automatic transmission (with manual shift) manufactured by America Dana, with 4 forward and 4 reverse gears available.
- **DRIVE AXLE:** D102PL341 heavy duty drive axle, manufactured by German Kessler.
- **TIRES:** 6 diagonal tires, Tire specifications: 18.00-25 40PR.
- **BRAKES:** Service brake: wet disc brake, acting on the front wheels, and equipped with independent cooling tank, high performance filter and radiator. Parking disc brake, acting on the front axle.
- **AIR CONDITIONER:** High power, automatic cooling and heating air conditioning.
- **STEERING:** Equipped with full hydraulic power steering, and easy to use.
- **HYDRAULIC SYSTEM:** America Parker variable plunger pump and valve, the system has compound action, high and low speed automatic switching (high speed when unloaded, low speed when loaded), vertical lifting and spreader anti-swing function. Equipped with high performance filter and high power independent radiator.
- **ELECTRIC SYSTEM:** 24V Can bus control system, two batteries, negative ground. Driving lights: three headlights, two turning signals in front of the vehicle; two turning signals, two brake lights and two reversing lights behind the vehicle. Working lights: four working lights at the spreader locks, four working lights at the middle of the boom, four working lights behind the vehicle. Warning lights: one rotating alarm lamp at the back of the vehicle.
- **FRAME:** Frame is made of high tension steel, with anti-torsion large cross-section.
- **SAFETY DEVICES:** LMT, anti-tilting protection device for rear axle, 2.5m long distance astern radar, one 2kg fire extinguisher, automatic fire extinguishing system.
- **BOOM:** Two-stage, quadrangular telescopic boom, anti-torsion design, is made of high tension steel.



☎ 1300 BROOKS (276 657)

@ sales@brooksequipment.com.au

🌐 www.brooksequipment.com.au

#### KEY SPECIFICATIONS

Length	11340 mm
Width (spreader)	6053 mm
Width (front wheel)	4200 mm
Height	4670 mm
Wheelbase	6000 mm
Trace (front)	3033 mm
Trace (rear)	2790 mm
Overhang (front)	840 mm
Overhang (rear)	1194 mm
Min. ground clearance	350 mm
Min. turning radius	8000 mm
Max. drawbar pull	380 kN
Max. gradeability	33%
Dead weight	71200 kg
Rated lifting capacity	45000 kg
Stacking capacity	5-5-4
Max. lifting height	15375 mm
Max. lifting speed (unloaded)	425 mm/s
Max. lifting speed (rated load)	250 mm/s
Max. lowering speed (unloaded)	360 mm/s
Max. lowering speed (rated load)	300 mm/s
Max. travelling speed (unloaded)	25 km/h
Max. travelling speed (rated load)	21 km/h
Aisle width (20')	11300 mm
Aisle width (40')	13600 mm

#### SPREADER SPECIFICATIONS

Lifting capacity	45000 kg
Side shift	± 800 mm
Telescoping time (Extending)	25 s
Telescoping time (Retracting)	11 s
Rotating time	50 s
Shifting time	15 s
Lock/unlock time	1s

#### DIMENSIONS OF TRANSPORTED PARTS

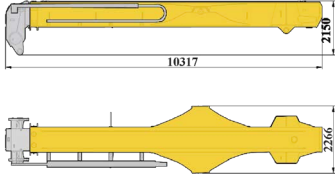
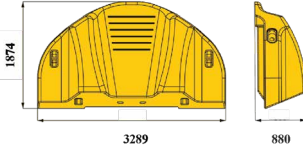
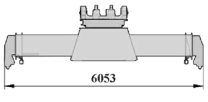
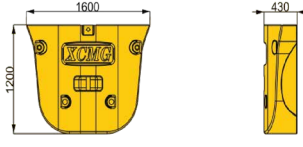
- |  |   |
|--|---|
| 1 Weight: 15617 kg   | 3 Weight: 15000 kg  |
|  |  |
| 2 Weight: 8120 kg  | 4 Weight: 3980 kg   |
|  |  |
| 5 Weight (with counterweight): 34400 kg  |   |
| Weight (without counterweight): 30500 kg   |   |
| Length (with counterweight): 8130 mm   |   |
| Length (without counterweight): 7700 mm  |   |

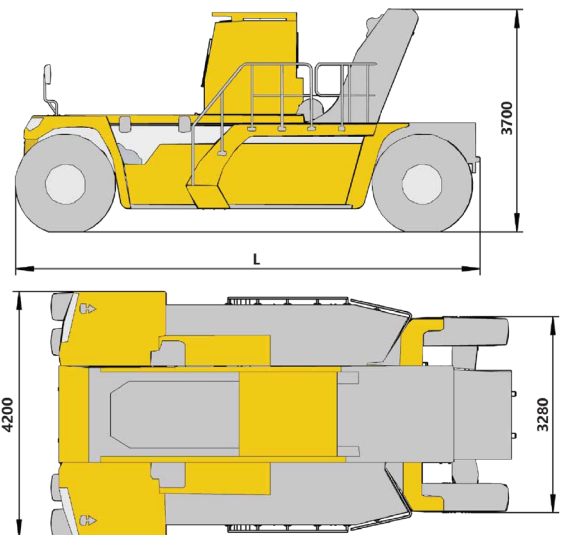

### DIMENSIONS

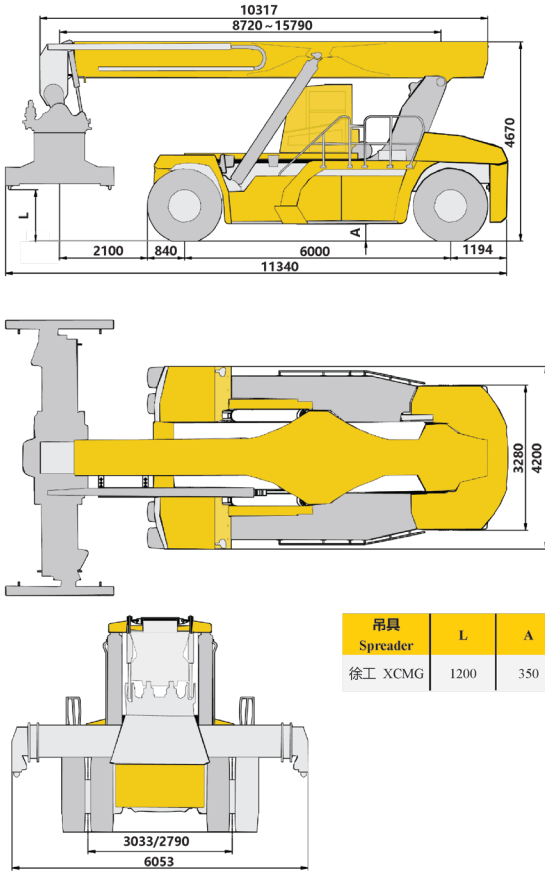

吊具 Spreader	L	A
徐工 XCMG	1200	350

### AISLE WIDTH

