

OPTIMUM OPERATION



SKID STEER
XC7-SR12

Product Specifications

RATED LOAD
1260 kg

RATED POWER
61.3 kW/2500 RPM

BUCKET CAPACITY
0.6m³

ENGINE
Yanmar 4TNV98T

SPECIFICATIONS

The XCMG XC7-SR12 is an innovative skid steer loader with upgraded technology and improved performance. Featuring excellent safety, reliability, advanced technology, and efficiency, it's ideal in a variety of applications such as road construction, maintenance, cleaning, construction, forestry, garden landscaping, agriculture, slope paving and levelling, and lifting and handling.

FEATURES

- The radial lifting mechanism independently designed by XCMG features higher lifting capacity and one-way leveling function, which is able to ensure higher operation efficiency.
- The panoramic cab is configured with FOPS and ROPS devices as standard to ensure higher safety and reliability.
- The spaceship-style cockpit features the electronic real-time monitoring system with intelligent advanced screen, which combines the design and performance perfectly, and improves the level of intelligence and comfort significantly.
- Switchover to high-flow mode with one button, enabling easy coupling of heavy-duty tools such as planer and disc saw to meet the needs for wider range of applications.
- Drivetrain system: well-known brand engine with excellent power performance and environmental-friendly emission certified according to China III requirements; maintenance-free sprocket box designed with long wheelbase and adapted to various ultra-heavy-duty operating conditions, featuring incomparable stability.
- Hydraulic system: key components from world-class brands, supporting boom lifting and leveling operations, as well as stepless speed regulation and intelligent control of coupled tools. Locking, centralized pressure measurement and parking brake functions; ensuring fast and efficient transfer with a driving speed up to 14km/h, surpassing competitors in the industry.
- Operating unit: Radial lifting mechanism independently designed by XCMG, featuring higher lifting capacity, universal quick couplings enabling easy change of various operating units to meet different operating requirements.
- Electric control system: electro-hydraulic control, higher safety with electric control interlock (inter - lock override).

MAINTAINABILITY

- The cab can be tipped over at a large angle, and the rear and upper hoods can be rotated to open. The quickly-detachable side panels and foot compartment enable convenient repair and maintenance of vehicle components.
- Cockpit maintainability: All electrical components (battery, fuses and switches), filter and oil drain port are easily accessible.
- The combined pressure testing connector can quickly test the pressure of the hydraulic system, and efficiently analyse and eliminate system faults.

COMFORT DESIGN

- The super-large luxurious cab is integrated with XCMG family-style design and C-type appearance, featuring spacious room and wide field of view.
- The air conditioner features excellent performance due to optimised internal air duct, balanced flow field and stable temperature control, and is configured with eight air outlets and supports glass defrosting and foot warming functions.
- The machine is equipped with hydraulic pilot + hydraulic control & multi-functional electric control to improve operating comfort.
- The mechanical suspension seat, featuring anti-vibration performance according to the EM9 standard, can be adjusted at different angles according to the comfort of the human body, and is configured with a 2" wide seat belt as standard.

PRODUCT RELIABILITY

- Warm-up idle speed: able to reach the operating temperature more quickly by increasing the engine idle speed slightly after the vehicle is started in the cold state.
- Engine monitoring and alarm: monitoring the coolant temperature, engine oil pressure, hydraulic oil temperature, etc.; producing an alarm and displaying the fault code in case the measured data exceeds the set value.
- Overload protection: able to limit the output torque and speed of the engine in case of overload for a prolonged duration, in order to prevent overheating and damage, minimise wear and avoid further failures.
- The welded sprocket box is integrated with the frame, featuring high structural strength, easy disassembly/assembly, and zero maintenance.
- High-strength roller bearings can withstand large radial and axial loads, and guarantee better performance under vibration and impact load conditions.



☎ 1300 BROOKS (276 657)

@ sales@brooksequipment.com.au

🌐 www.brooksequipment.com.au

WORKING PARAMETERS

Rated load	1260 kg
Bucket capacity	0.6 m ³
Operating mass	3680 kg
Rated power of the engine	61.3 kW
Rated speed of the engine	2500 rpm
Dumping height	2530 mm
Dumping range	600 mm
Wheel base	1316 mm
Wheel track	1500 mm
Max breakout force	30 kN
Max tractive force	32 kN
Total cycle time	≤10 s
Max. driving speed	12 km/h
Overall dimensions (L x W x H)	3760*2000*2040 mm

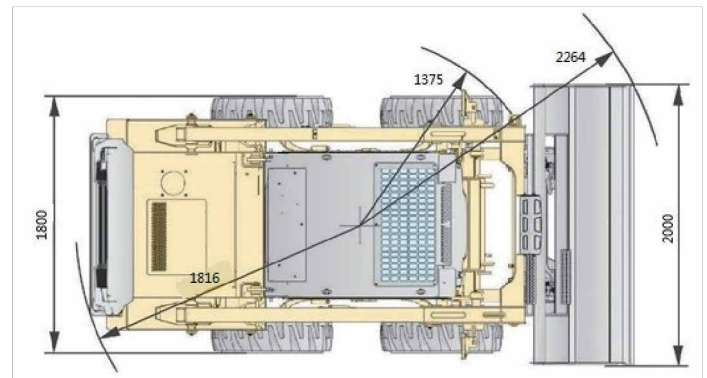
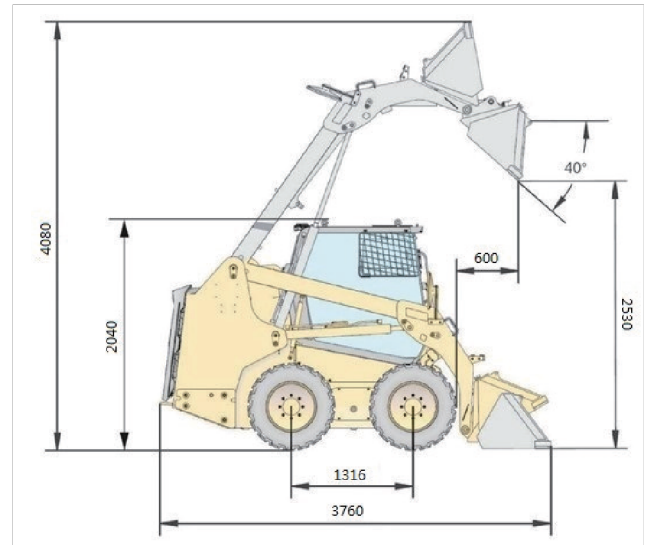

SYSTEMS

Engine	Yanmar 4TNV98T
Type	Inline four-cylinder, naturally aspirated, high pressure common rail
Displacement	3.319 L
Max. torque	269.3~293.5/1850±100 Nm/rpm
Emission standard	Non-road China III
Cab ROPS	According to ISO 3471:2008
Cab FOPS	According to ISO 3449:2005 Level 1
Tyre	12-16.5
Standard auxiliary flow	95 L/min
High auxiliary flow	156 /min
Hydraulic pressure	210 bar
Air Conditioning	Cooling and heating



☎ 1300 BROOKS (276 657)

@ sales@brooksequipment.com.au

🌐 www.brooksequipment.com.au