

DESIGNED FOR OPERATOR EFFICIENCY



FORKLIFT

XCF1612KII

Product Specifications

OVERALL WEIGHT
23,600 kg

RATED CAPACITY
16,000 kg

MAX. LIFTING HEIGHT
4,000 mm

ENGINE
Cummins QSB6.7

STANDARD EQUIPMENT

- **CAB:** The integrated design of driving and operating functions makes the appearance simple and dynamic. Panoramic, low Instrument panel and Ergonomically designed inner space bring wide field of vision and comfortable experience. Equipped with large screen display, the machine is easy to use. The electric auxiliary hydraulic drive tipping system makes the internal maintenance convenient and fast.
- **ENGINE:** QSB6.7, inline six-cylinder water-cooled turbocharged electric-control diesel engine, manufactured by Cummins; Rated power 142 kW/2300rpm, max. torque 930 Nm / 1500 rpm; Emission compliance: compliant with off-road U.S. EPA Tier 3/EU Stage IIIA.
- **TRANSMISSION:** TE series automatic transmission (with manual shift) manufactured by DANA America, with 3 forward and 3 reverse gears available. The speed control valve is a proportional control valve, which is easy to operate. the speed control and micro valve control adopt electronic control is adopted for the micro valve control, which makes the driving and heavy load micro control of forklift more accurate.
- **DRIVE AXLE:** D81, German KESSLER heavy duty drive axle, axle. Eequipped with a wet multi-disc travel brake, the system is fully enclosed and maintenance-free, which can adequately cope with heavy working conditions and bring high reliability and easy maintenance.
- **TIRES:** 6 diagonal tires, with large bearing capacity and special heavy forklift pattern, are suitable for various working conditions of counterweight forklift products. Tire specifications: 12.00-20-20PR.
- **SUSPENSION:** Front axle is rigidly connected with frame for high stability while driving with a container suspended; rear axle is hinged with frame for buffering road shock through the hinged mechanism.
- **AIR CONDITIONER:** High power, automatic cooling and heating air conditioning.
- **BRAKES:** Service brake: wet disc brake, acting on the front wheels. Automatic braking is available in case of lower system pressure. Parking brake: spring-loaded brake and hydraulic-released independent disc brake, acting on the front axle.
- **STEERING:** Rear axle full hydraulic power steering, steering light and reliable. The minimum turning radius is 5050mm.
- **HYDRAULIC SYSTEM:** The load sensitive hydraulic system of variable pump not only ensures the rapid lifting requirements during loading and unloading operation, but also reduces the continuous load of engine from the source, which is truly efficient and energy-saving. Adopted international famous brand products, the components of system are mature and stable.
- **ELECTRIC SYSTEM:** DC 24 V, negative ground, 2 batteries. There are headlamps, reverse lamp and turn lamps available in lighting system. Due to the CANBUS bus control, the system is stable and safe Fault display and convenient diagnostic instrument socket greatly simplify the repair and maintenance.
- **FRAME:** Frame is made of fine grain high tension steel, with anti-torsion large cross-section, strong carrying capacity. Finite element analysis and zero order design optimization method adopted for key structures ensure the strength and stiffness of structural members.
- **MAST:** The telescopic mast with wide field of vision adopts anti twist design, which has good operation performance, strong anti twist ability and excellent vision.
- **FORK:** High strength forged fork. Side shift distance fork, fort movement is driven by oil cylinder, with the function of side shift adjusting distance.



☎ 1300 BROOKS (276 657)

@ sales@brooksequipment.com.au

🌐 www.brooksequipment.com.au

KEY SPECIFICATIONS

Rated lifting capacity	16000 kg
Overall length	7975 mm
Overall width (Wheel)	2570 mm
Overall width (Frame)	2570 mm
Overall height (Min. mast height)	3340 mm
Overall height (Cab height)	3355 mm
Overall height (Max. mast height)	4840 mm
Wheel base	3750 mm
Front overhang	1040 mm
Track (Front)	1895 mm
Track (Rear)	2120 mm
Min. ground clearance (Under mast unloaded/ rated load)	275 mm
Min. ground clearance (Middle of tuck unloaded/ rated load)	300 mm
Max. lifting height	4000 mm
Mast tilting (Forwards/backwards)	6/12°
Dead weight	23600 kg
Max. lifting speed (Unloaded)	410 mm/s
Max. lifting speed (rated load)	360 mm/s
Max. lowering speed (Unloaded)	400 mm/s
Max. lowering speed (Rated load)	400 mm/s
Min. turning radius	5050 mm
Travelling speed (Unloaded)	29 km/h
Travelling speed (Rated load)	26 km/h
Max. gradeability	23%
Max. drawbar pull (rated load)	182 kN

DIMENSIONS

Fork length A/mm	2440
Load centre D/mm	1200
Overall length L1/mm	7975

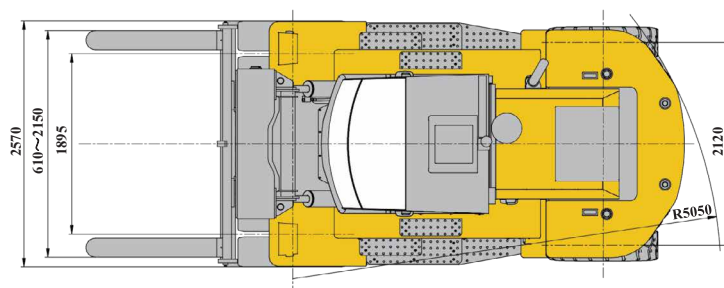
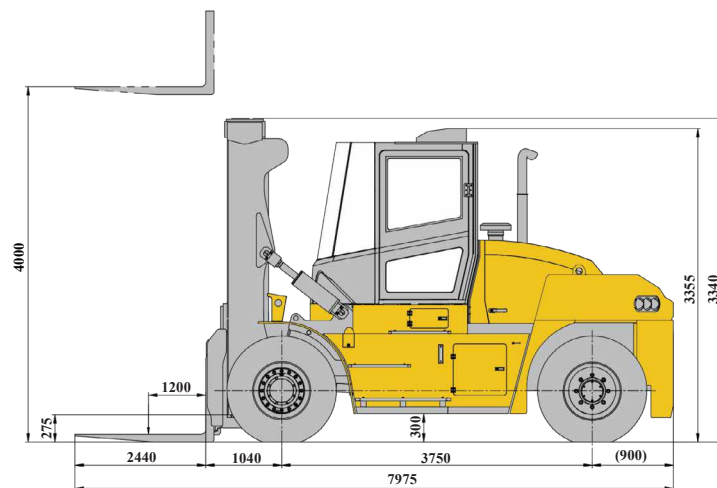

☎ 1300 BROOKS (276 657)

@ sales@brooksequipment.com.au

🌐 www.brooksequipment.com.au