

# OPERATOR COMFORT & EASE OF USE



**FORKLIFT**  
**XCF1606K**

Product Specifications

OVERALL WEIGHT  
**19,500 kg**

RATED CAPACITY  
**16,000 kg**

MAX. LIFTING HEIGHT  
**3,000 mm**

ENGINE  
**Cummins QSB6.7**

#### STANDARD EQUIPMENT

- **CAB:** The integrated design of driving and operating functions makes the appearance simple and dynamic. Panoramic, low Instrument panel and ergonomically designed inner space bring wide field of vision and comfortable experience. Equipped with large screen display, the machine is easy to use. The electric auxiliary hydraulic drive tipping system makes the internal maintenance convenient and fast.
- **ENGINE:** Engine QSB6.7, inline six-cylinder water-cooled turbocharged electric-control diesel engine, manufactured by Cummins. Rated power 119 kW/2300rpm, max. torque 731 Nm / 1500 rpm. Emission compliance: compliant with off-road U.S. EPA Tier 3/EU Stage IIIA.
- **TRANSMISSION:** 3WG131, automatic transmission (with manual shift) manufactured by ZF Germany, with 3 forward and 3 reverse gears available. The speed control valve is a proportional control valve, which is easy to operate. The speed control and micro valve control are electronic, making the driving and heavy load micro control, more accurate.
- **DRIVE AXLE:** 18MRZWA-X211JA, Xuzhou Meritor heavy duty drive axle. Equipped with a wet multidisc travel brake, the system is fully enclosed and maintenance-free, which can adequately cope with heavy working conditions and bring high reliability and easy maintenance.
- **TIRES:** 6 diagonal tires, with large bearing capacity and special heavy forklift pattern, are suitable for various working conditions of counterweight forklift products. Tire specifications: 12.00-20-20PR.
- **SUSPENSION:** Front axle is rigidly connected with frame for high stability while driving with a container suspended. Rear axle is hinged with frame for buffering road shock through the hinged mechanism.
- **AIR CONDITIONER:** High power, automatic cooling and heating air conditioning.
- **BRAKES:** Service brake: wet disc brake, acting on the front wheels. Automatic braking is available in case of lower system pressure. Parking brake: spring-loaded brake and hydraulic-released independent disc brake, acting on the front axle.
- **STEERING:** Rear axle full hydraulic power steering, steering light and reliable. The minimum turning radius is 4450mm.
- **HYDRAULIC SYSTEM:** The machine adopts a hydraulic gear pump system that's simple and reliable. A high power, air cooled hydraulic oil radiator is used to cool the system.
- **ELECTRIC SYSTEM:** DC 24 V, negative ground, 2 batteries. Utilising the CANBUS bus control, the system is stable and safe. Fault display and convenient diagnostic instrument socket greatly simplifies repairs and maintenance.
- **FRAME:** Frame is made of fine grain high tension steel, with anti-torsion large cross-section and a strong carrying capacity. Finite element analysis and a zero order design optimisation method is adopted for key structures to ensure the strength and stiffness of structural members.
- **MAST:** The telescopic mast with wide field of vision adopts anti twist design, which has good operation performance, strong anti-twist ability and excellent vision.
- **FORK:** High strength forged, adjustable fork. The fork movement is driven by an oil cylinder, with the function of adjusting distance.



☎ 1300 BROOKS (276 657)

@ sales@brooksequipment.com.au

🌐 www.brooksequipment.com.au

#### KEY SPECIFICATIONS

Rated lifting capacity	16000 kg
Overall length	6265 mm
Overall width (Wheel)	2570 mm
Overall width (Frame)	2570 mm
Overall height (Min. mast height)	3385 mm
Overall height (Cab height)	3355 mm
Overall height (Max. mast height)	4885 mm
Wheel base	3250 mm
Front overhang	795 mm
Track (Front)	1888 mm
Track (Rear)	2120 mm
Min. ground clearance (Under mast unloaded/ rated load)	275 mm
Min. ground clearance (Middle of tuck unloaded/ rated load)	300 mm
Max. lifting height	3000 mm
Mast tilting (Forwards/backwards)	6/12°
Dead weight	19500 kg
Max. lifting speed (Unloaded)	400 mm/s
Max. lifting speed (rated load)	350 mm/s
Max. lowering speed (Unloaded)	400 mm/s
Max. lowering speed (Rated load)	400 mm/s
Min. turning radius	4450 mm
Travelling speed (Unloaded)	30 km/h
Travelling speed (Rated load)	28 km/h
Max. gradeability	23%
Max. drawbar pull (rated load)	145 kN

#### DIMENSIONS

Fork length A/mm	1370
Load centre D/mm	600
Overall length L1/mm	6265

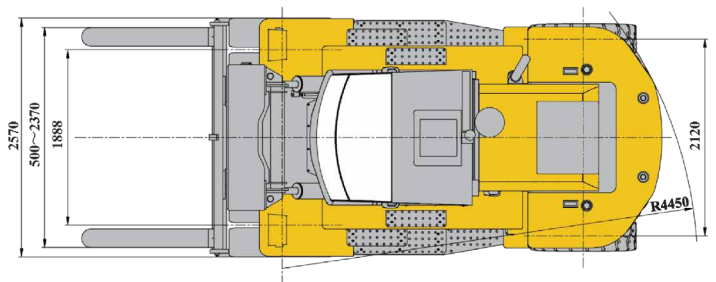
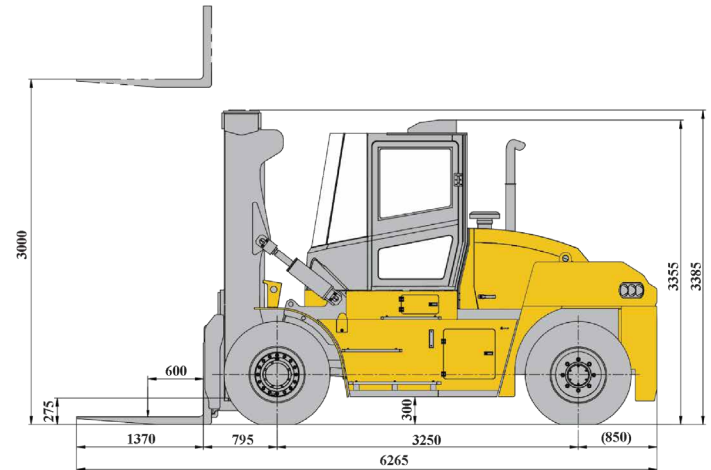

☎ 1300 BROOKS (276 657)

@ sales@brooksequipment.com.au

🌐 www.brooksequipment.com.au