

# FOR YOUR SUCCESS



## FORKLIFT **FGL25T**

Product Specifications

OVERALL WEIGHT	3,628 kg
RATED CAPACITY	2,267 kg
MAX. LIFTING HEIGHT	2,997 mm
ENGINE	Nissan K25(T4)

### SPECIFICATIONS

#### GENERAL

Model	JHN FGL25T
Power type	Gasoline/LPG
Rated load capacity (Q)	5000 lb
Load centre (C)	24 in

#### CHARACTERISTICS & DIMENSIONS

Rated lift height (H3)	118 in
Free lift height (H2)	3.9 in
Fork size (LxWxT)	42x4.7x1.5 in
Mast tilt angle	6°/12°
Fork overhang (wheel center to fork face) (X1)	18.8 in
Rear overhang (X2)	20 in
Ground clearance (bottom of mast) (H7)	5 in
Length to face of fork (without fork) (L1)	104 in
Overall width (B1)	45 in
Mast lowered height (H1)	81 in
Mast extended height (without backrest) (H4)	160 in
Overhead guard height (H5)	87 in
Turning radius (outside) (Wa)	93 in
Min. aisle width for pallets (Ast)	162 in

#### PERFORMANCE

Travel speed (no load)	19 km/h
Lifting speed (full load)	19 in/sec
Wheelbase	65 in
Max. gradeability (full load)	20%

#### WEIGHT

Total weight	8000 lb
Front axle weight distribution (full load/ no load)	12112/3179 lb
Rear axle weight distribution (full load/ no load)	13444/4768 lb

#### POWER & TRANSMISSION

Engine model	K25(T4)
Engine manufacturer	Nissan
Rated output / rpm	43/2700 kW
Battery	12/90 V/Ah
Transmission type	Powershift / Manual
Transmission stage (FWD/RVS)	1/1(2/2)
Operating pressure (for attachments)	17.5 Mpa

#### DIMENSIONS

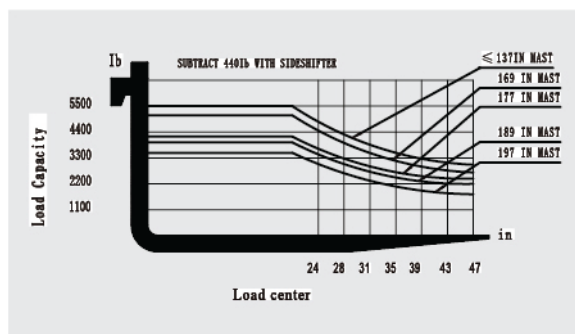
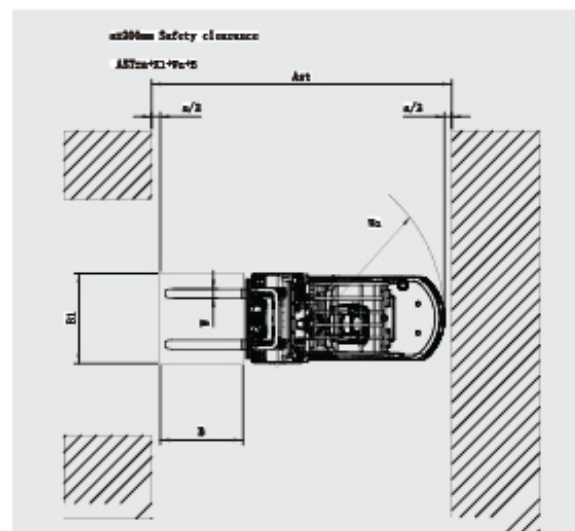
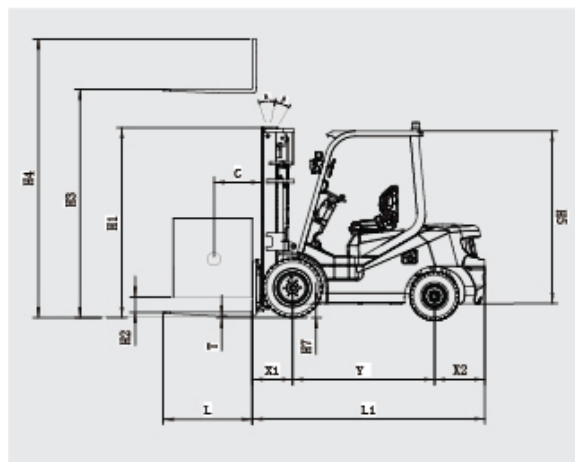

☎ 1300 BROOKS (276 657)

@ sales@brooksequipment.com.au

🌐 www.brooksequipment.com.au