

BROOKS
EQUIPMENT



SANY



**NOWHERE IS
OUT OF REACH**



MINI EXCAVATORS

SY16C | SY18C

Product Specifications

OPERATING WEIGHT
1,750 kg / 1,850 kg

RATED POWER
14.6 kW / 2400 rpm

BUCKET CAPACITY
0.04m³

ENGINE
Yanmar 3TNV80F

SANY

For challenging tasks, you need a first-class partner

Quality comes from experience. And from new ideas. This is why we combine these two crucial factors at SANY. This is because we are one of the world's leading producers, having sold more than **250 000** excavators in **10 years**. This means that you can always rely on sophisticated products that have been tried and tested in practice. An impressive **5–7%** of our annual turnover is dedicated to research and development. This is why we give you not only our word, but also our extraordinary **five-year warranty** as a guarantee of how powerful and robust our products are.

250 000
EXCAVATORS SOLD IN
10 YEARS

5–7%
TURNOVER FOR RESEARCH
AND DEVELOPMENT

**FIVE-YEAR
WARRANTY***

Quality Changes the World

* Applicable in certain markets, please check with your local dealer.



SY16C | SY18C

COPEs WELL WITH LITTLE SPACE

Whenever things get tight, the SANY SY18C mini excavator is just right. Measuring just 980 mm in width, it even fits through narrow passages, making it the ideal solution for garden and landscaper construction and for work directly on buildings or in existing buildings. Its outstanding equipment is also impressive – take, for example, the width-adjustable chassis, the versatile proportional hydraulics of the auxiliary control circuit or the bright LED work lights.

Weighing in at just 1 850 kg and with a transport height of only 2 420 mm, it is also very easy to transport, can be loaded and unloaded quickly and impresses on site with its excellent manoeuvrability in confined spaces. At the same time, it does not compromise on efficiency in any way – for example, it stands out with a maximum horizontal reach of up to 4 000 mm. **It is also available as a canopy version in the SANY SY16C version.**

SY18C HARD FACTS

Max. bucket digging force
15.2 kN (ISO)

Max. arm digging force
9.2 kN (ISO)

Swingspeed
10 rpm

Max. travel speed
3.8 km/h

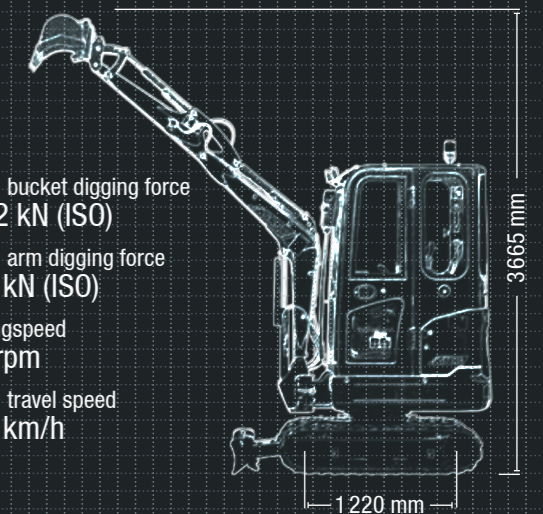

1300 BROOKS (276 657)

@ service@brooksequipment.com.au

www.brooksequipment.com.au

BROOKS
EQUIPMENT

QUALITY

Robust and durable – the most important protective elements and reinforcements as well as all cladding parts are made of high-quality metal, ideal for tough use in the construction industry.

DIMENSIONS

Lightweight and compact – the SY18C fits easily onto standard car trailers and can be transported quickly to any location, even where space is tight.

USER EXPERIENCE

Extremely comfortable – from easy access to the comfortable seat and the ergonomically designed controls, drivers can look forward to maximum comfort.



SAFETY

No compromise – the SY18C is fully equipped for precise, safe working even in very confined application conditions. In addition to the standard rotating warning beacon, this also includes the battery disconnection switch and an emergency stop button.

COMPONENTS

Quality as standard – the SY18C already comes with extensive features as standard. In addition, it features core components such as the engine and pumps from renowned brand manufacturers like Yanmar and Casappa.

ECONOMY

Economically impressive – low procurement cost, economical consumption in compliance with emission standard 5 and straightforward maintenance which is attractive. When it comes to costs, SANY mini excavators really are mini.

AS PRECISE AS BY HAND – ONLY MUCH QUICKER

Mini excavators in particular require high operational flexibility. In this regard, the SY18C is simply unbeatable. It also has a powerful hydraulic system that gives it the necessary power. Together with the precise response behaviour of the hydraulics and chassis, this makes it a perfect precision tool.

QUALITY

Fully resilient – metal access panels

Durability and robustness are standard features on all SANY mini excavators. For example, the access panels parts are made exclusively of metal. This makes them particularly robust – and if a bump happens during the tough everyday work on a construction site, it can usually be repaired. This is what we mean by sustainability.

DIMENSIONS

Adjustable track frame to suit all your requirements and increase stability

When things get really tight, the SY18C makes itself very small – with a width of just 980 mm, it can even fit through a garden gate, a door opening or onto a trailer for transport. If stability is required, the chassis can be hydraulically adjusted to a width of 1 350 mm. The dozer blade can also be adjusted to the respective width.

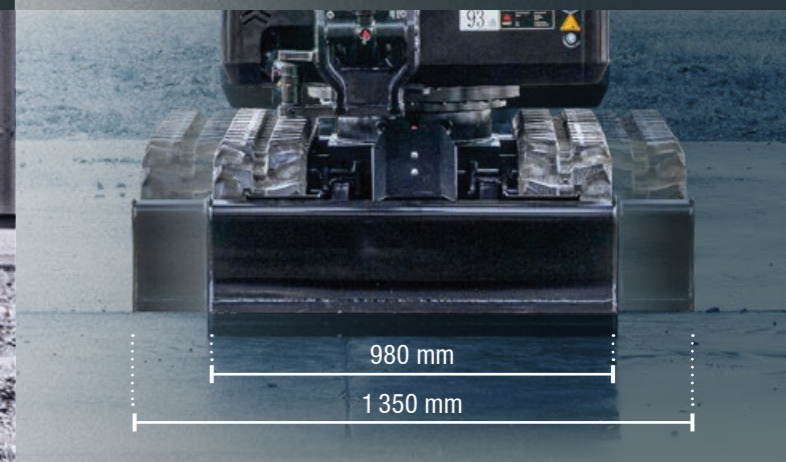

The added benefits SANY offers you:

- + Width-adjustable chassis
- + Cab or canopy
- + Proportional auxiliary control circuit via joystick operation as standard
- + Load-sensing hydraulic system
- + LED work lighting
- + Emission standard – Stage V



1300 BROOKS (276 657)
 @ service@brooksequipment.com.au
 www.brooksequipment.com.au

BROOKS
EQUIPMENT

SAFETY

Protection for people and machines

Thanks to the ROPS or FOPS-tested operator's platform, SANY's smallest model also performs well in terms of safety. To ensure that people and machines, tools and buildings and the environment are optimally protected, the standard equipment includes a battery disconnection switch and an emergency stop button. The rotating warning beacon and the travel alarm helps the operator to pay attention to their work during operation.



COMPONENTS

The individual that already has everything

Many things that are good are already standard with the SY18C. For example, the LED work lights that guarantee optimum views in all conditions. Or the sophisticated load-sensing hydraulic system with precise power adjustment to meet current requirements.



USER EXPERIENCE

Maintenance done the easy way

Only a well maintained machine can do a good job. Therefore, all maintenance-relevant parts of the SY18C are easily accessible from ground level. This saves time and money during regular inspections and all maintenance work and increases availability.

The fuel tank is also easy to reach – but with a tank capacity of 23 litres and low fuel consumption, you do not need to refuel as often anyway.

ECONOMY

Your very personal little economic miracle

For great performance in the smallest of spaces, you need a real powerhouse: Agile and extremely compact, flexible and precise. The SY18C gets to the heart of maximum power – for quick and clean results where only manual work would otherwise be possible. This makes it a highly efficient tool. In addition, the SY18C offers an attractive price-performance ratio at the time of purchase and then in terms of operating costs.



Absolute reliability – for peace of mind!

SANY's five-year warranty* gives you the assurance that you can fully count on your equipment.

* With participating partners

USER EXPERIENCE

EVERYTHING PERFECTLY UNDER CONTROL

Precise handling, quick reactions, fatigue-free operation – the controls of the SY18C are designed for ergonomic handling. Designed for everyday use, all switches are easy to reach. Joysticks transmit movements directly and precisely. The digital display is clear and easy to read and shows the most important data at a glance. Using the small wheel in the joystick, the proportional function of the auxiliary control circuit can be easily controlled with the thumb.



ECONOMY

THE FINE DIFFERENCE: OPEN FOR ALL – SANY SY16C

Same technology, same performance – the SY16C differs from the SY18C only in that it is equipped as a canopy instead of a cab. It therefore weighs slightly less – just 1750 kg. The canopy variant offers a perfect view outside of the work area while meeting current ROPS requirements.



1300 BROOKS (276 657)
 @ service@brooksequipment.com.au
 www.brooksequipment.com.au

ENGINE

Model	Yanmar 3TNV80F
Typ	Water-cooled four-stroke diesel engine with turbulence chamber fuel injection
Exhaust emissions	Stage V
Rated power	14.6 kW / 2400 rpm
Max. torque	64.7 Nm / 1800 rpm
Displacement	1267 ccm
Batteries	1x 12 V / 60 Ah

HYDRAULIC SYSTEM

Main pump	Variable displacement axial piston pump
Max. oilflow	72 l/min
Travel motor	Variable displacement axial piston motor
Rotation device	Axial piston motor
Max. oilflow (AUX1)	28 l/min

RELIEF VALVE SETTINGS

Implement circuit	245 bar
Swing circuit	162 bar
Travel circuit	245 bar
Pilot pressure	35 bar

SERVICE REFILL CAPACITIES

Fuel tank	23 l
Engine coolant	4.1 l
Engine oil	3.4 l
Drive (per side)	0.4 l
Hydraulicsystem	26 l
Hydraulic oil tank	21 l

PERFORMANCE

Swingspeed	10 rpm
Max. travel speed	High 3.8 km/h, slow 2.2 km/h
Max. travel force	15.6 kN
Bucket capacity	0.04 m ³
Ground pressure	0.29 kg/cm ² / 0.31 kg/cm ²
Gradeability	30°
Bucket digging force ISO	15.2 kN
Arm digging force ISO	9.2 kN

OPERATING MASS

SY16C	1750 kg
SY18C	1850 kg

UNDER AND UPPER STRUCTURE

Boom length	1810 mm
Arm length	1130 mm
Bottomrollers	3
Rotation device	Axial piston motor with planetary gear running in oil bath and single-row slewing ring. Slewing gear parking brake, hydraulically released.
Undercarriage	Reinforced lower structure with larger dimensions. Welded drive frame in box design made of special material. Side frame telescopic.

LIFTING CAPACITIES OF LOWER DOZER BLADE

Load point height	Radius				Digging reach	
	1.5 m / 4.9 ft	2.0 m / 6.6 ft	2.5 m / 8.2 ft	3.0 m / 9.8 ft	Maximal	Maximal
3.0 m kg					285	285
9.8 ft lb					627	627
2.0 m kg			267	253	271	271
6.6 ft lb			587	557	596	596
1.0 m kg		483	486	371	370	306
3.3 ft lb		1063	1063	816	814	673
Ground line	kg	826	826	631	528	456
	lb	1817	1817	1388	1162	1003
-1.0 m kg		819	819	563	529	407
-3.3 ft lb		1802	1802	1239	1164	895
					840	
					700	700

LIFTING CAPACITIES OF UPPER DOZER BLADE

Load point height	Radius				Digging reach	
	1.5 m / 4.9 ft	2.0 m / 6.6 ft	2.5 m / 8.2 ft	3.0 m / 9.8 ft	Maximal	Maximal
3.0 m kg					285	285
9.8 ft lb					627	627
2.0 m kg			253	253	271	271
6.6 ft lb			557	557	596	596
1.0 m kg		483	483	370	370	296
3.3 ft lb		1063	1063	814	814	651
Ground line	kg	811	826	514	528	371
	lb	1784	1817	1131	1162	816
-1.0 m kg		819	819	514	529	370
-3.3 ft lb		1802	1802	1131	1164	814
					840	
					695	700

DIMENSIONS (TRANSPORT)

A	Transport length	3640 mm
B	Transport width	980/1350 mm
C	Upperstructure carriage	980 mm
D	Height over cabin/ROPS	2420 mm
E	Height of Boom – transport	1175 mm
F	Overall length of crawler	1585 mm
G	Tail length	900 mm
H	Track gauge	750/1120 mm
I	Undercarriage width (blade)	980/1350 mm
J	Horizontal distance to blade	1190 mm
K	Blade height	280 mm
L	Track height	375 mm
M	Track pads width	230 mm
N	Min. ground clearance	180 mm
O	Counterweight clearance	470 mm
P	Engine cover height	1275 mm
Q	Tail swing radius	920 mm
R	Center distance of tumbler	1220 mm

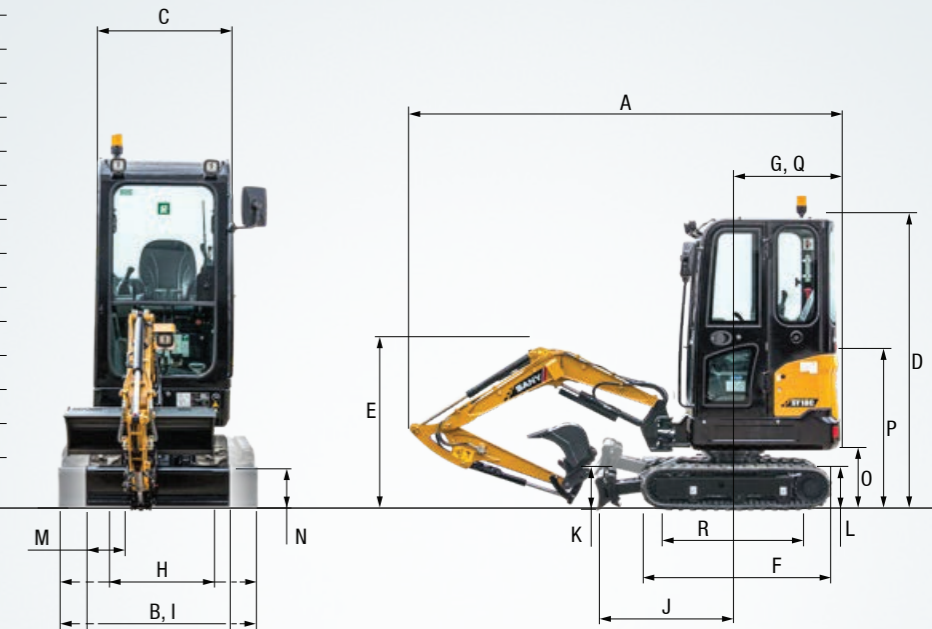

WORKING AREA

A	Max. digging reach	4000 mm
B	Max. digging depth	2360 mm
C	Max. digging height	3665 mm
D	Max. dumping height	2635 mm
E	Min. dumping height	795 mm
F	Max. vertical digging depth	2215 mm
G	Overall height over arm by min. swing radius	2745 mm
H	Arm head distance with work equipment retracted as far as possible	1230 mm
I	Swing radius by max. boomswing (L)	1490 mm
	Swing radius by max. boomswing (R)	1510 mm
	Min. swing radius	1705 mm
J	Max. clearance when blade up	310 mm
K	Max. depth of blade down	320 mm
L	Offset boom (L)	595 mm
	Offset boom (R)	350 mm
	Max. boom-swing angle (L)	73°
	Max. boom-swing angle (R)	46°

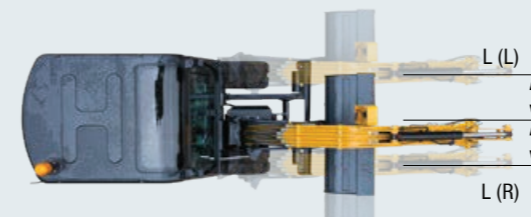
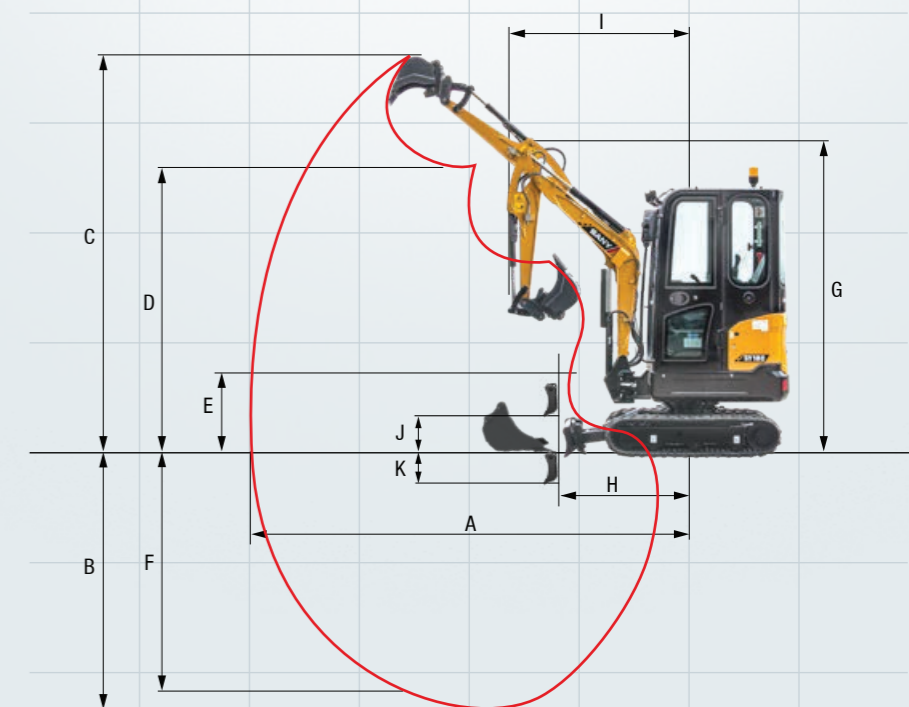

Amazingly well equipped for their size

Although the SY16C and SY18C are the smallest and lightest of the SANY mini excavators, they still have everything you need for efficient, precise work on board as standard.



OPERATORS COMFORT / CABINE

Heater	●	●
Radio and speaker	●	●
Armrests (adjustable)	●	●
12v outlets	●	●
Wiper	●	●
Sprayer f. wiper	●	●
AUX 1 on Joystick	●	●
Removable front-window	●	●
Sky light	●	●

SAFETY

Battery master switch	●	●
Beaconlamp	●	●
Lockable hoods	●	●
Lockable fuel cap	●	●

WORKING EQUIPMENT

Boom and arm load holding valves with overload indicator	opt.	opt.
Double acting circuit for hydraulic quick coupler with piping	opt.	opt.
Breaker&Shear line proportional on Joystick with piping	●	●
Rotation line proportional on Joystick with piping	opt.	opt.
Cylinder guardes – boom	●	●

● SY16C ● SY18C

The standard and special options differ depending on the country in which the mini excavator is delivered. If you have any questions, please contact your dealer directly.

WORKING LIGHTS

2 x Lights front (LED)	●	●
1 x Light boom (LED)	●	●

UNDERCARRIAGE

Telescopic thread	●	●
Rubber tracks	●	●
Steel tracks	opt.	opt.
Cylinder guardes – dozer blade	●	●
Holes/loops for fixing	●	●

ENGINE

Diesel filter	●	●
Dehydr. For fuelsystem	●	●
Cage or storage for grease gun	●	●
Air filter guard	●	●

HYDRAULIC SYSTEM

2 speed travel	●	●
Piping for additional hydraulic function AUX 1	●	●
Hydr. Pre-pressure operating joysticks	●	●
Mainfilter	●	●

A SERVICE YOU CAN RELY ON

Just as we do with our excavators, we also demand high quality and reliability of our service products. This underlines our equipment's performance in terms of their durability and their excellent price-performance ratio. After all, maintenance is crucial

for efficiency, cost-effectiveness and safety. Your SANY dealer is happy to help you with a comprehensive range of services to ensure that your machine continues operating efficiently in the long term.

SANY – flexible, fast and always there for you

Rapid assistance, tailored advice and a reliable supply of original parts – that is what we mean by a premium service.



The added benefits SANY offers you:

- + Fast supply thanks to the central warehouse near Cologne
- + More than 15,000 spare parts to make your machine highly reliable
- + Expert knowledge for optimal supply for your machine
- + Thanks to SANY's special training programme, our dealers are always kept up-to-date so that they can face all technical challenges.

Parts supply – quick and reliable

With the purchase of a SANY mini excavator you have made an investment in the future. Fast availability of spare parts is your guarantee of minimal downtimes and failure times.



Detailed information in black and white

Handbooks and documents are available for all SANY mini excavators, and these can help you with operation, maintenance, servicing and repairs. These include operating and maintenance instructions and technical specifications.



☎ 1300 BROOKS (276 657)

@ service@brooksequipment.com.au

🌐 www.brooksequipment.com.au

BROOKS

EQUIPMENT



EFFICIENT PERFORMANCE IN MINI FORMAT

Their extremely simple handling and flexible, precise operation make the mini-excavators a highly productive tool for every job. As lightweight machines with compact dimensions, they can also be transported quickly and easily to the place of use.

ROBUST AND DURABLE

The most important protective elements and reinforcements as well as all cladding parts are made of **robust metal**. **Robotic welded components** guarantee a long service life under all conditions.

EXTREMELY COMFORTABLE

Impressively simple thanks to the **joystick, which is easy to operate with high precision**, and the **clear display**.

NO COMPROMISE

In order to provide **the best possible protection for both people and machines**, devices such as cylinder guard plates are already integrated. It goes without saying that the platform is **ROPS or FOPS certified**.

TECHNICAL HIGHLIGHTS

Engine	Yanmar 3TNV80F
Rated power	14.6 kW / 2 400 rpm
Max. torque	64.7 Nm / 1 800 rpm
Max. travel speed	3.8 km/h
Swingspeed	10 rpm
Mainpump	Variable displacement axial piston pump
Max. oilflow	72 l/min

LIGHTWEIGHT AND COMPACT

Chassis adjustable in width – from extremely narrow when manoeuvring to wide for the best possible stability.

ECONOMIC

The intelligent control system adapts the pump capacity to the respective demand for **greater efficiency and reduced fuel consumption**.

QUALITY AS STANDARD

High-quality components from brand manufacturers guarantee top performance and a high level of operational safety – also for the **extensive standard equipment**. For example, these include the auxiliary control circuit, LED lighting and even the radio on cab machines.



**"EXCELLENT POWER AND CONTROLLABILITY
COMBINED WITH A VALUE ADDED PRICE!"**

Tim Berges –
Retzmann Bauunternehmen Tief- und Straßenbau GmbH

Not all products are available in all markets. As part of our continuous improvement process, we reserve the right to modify specifications and designs without giving prior notice. The figures may contain additional options.



☎ 1300 BROOKS (276 657)
@ service@brooksequipment.com.au
🌐 www.brooksequipment.com.au

BROOKS

EQUIPMENT